



**ALTAS<sup>®</sup>**  
**STRENGTH**

*AL-3058*

MULTI FUNCTION GYM

# Owner 's Manual

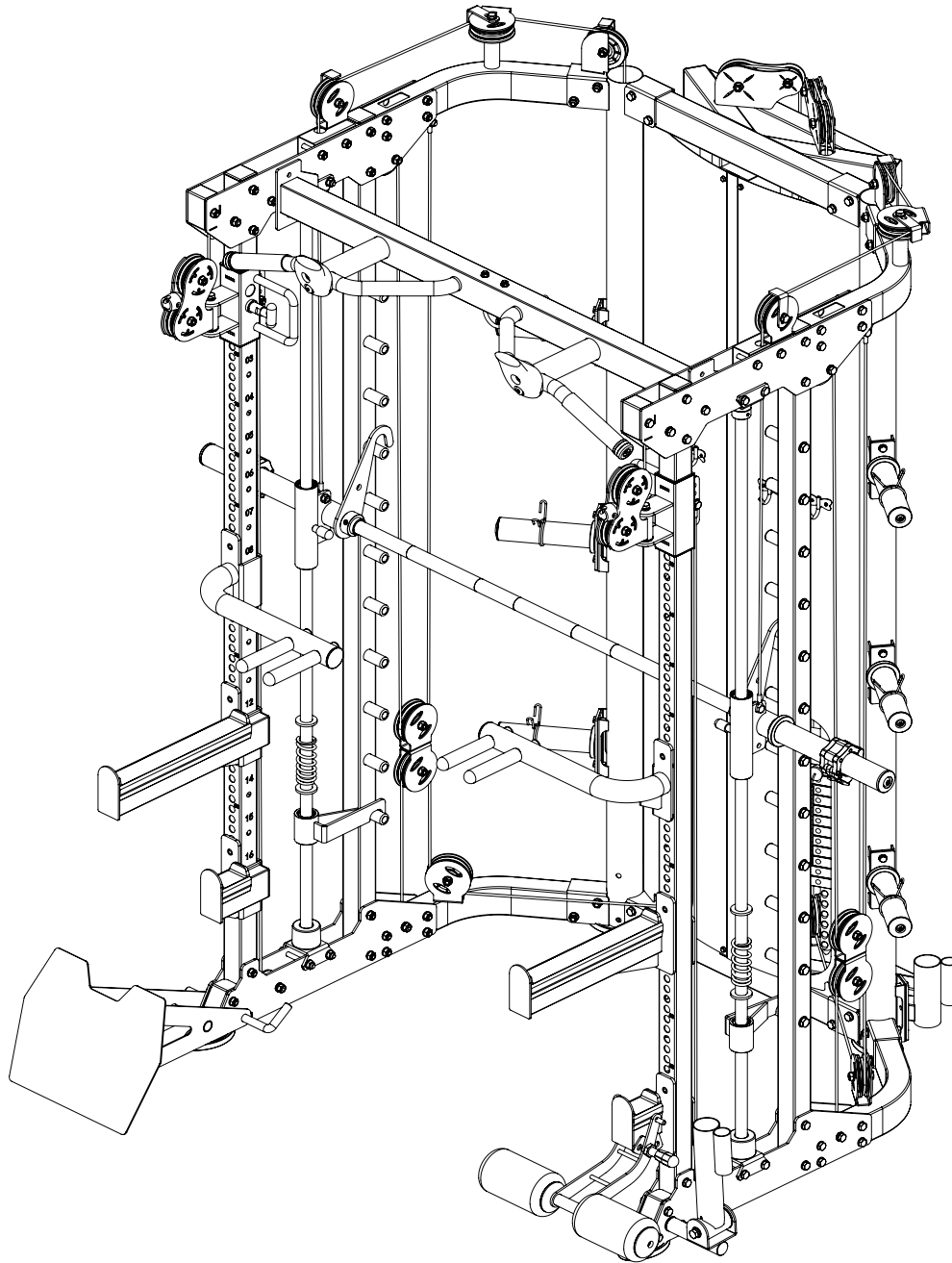

## TABLE OF CONTENTS

Parts List	3~5
Parts and Components List	6~7
Screw Tool Diagram	8
Assembly Step 1	9
Assembly Step 2	10
Assembly Step 3	11
Assembly Step 4	12
Assembly Step 5	13
Assembly Step 6	14
Assembly Step 7	15
Assembly Step 8	16
Assembly Step 9	17
Assembly Step 10	18
Assembly Step 11	19
Assembly Step 12	20
Assembly Step 13	21
Assembly Step 14	22
Assembly Step 15	23
Assembly Step 16	24
Assembly Step 17	25~26
Assembly Step 18	27~28
Assembly Step 19	29~30
Assembly Step 20	31
Assembly Step 21	32
Assembly Step 22	33
Assembly Step 23	34
Assembly Step 24	35
Accessory List	36

### Measuring For Bolt Length



## PARTS LIST

NO.	DESCRIPTION	NOTE	QTY
1	Connection Tube	Assembly Part	1
2	Upright Frame Left	Assembly Part	1
3	Upright Frame Right	Assembly Part	1
4	Bending Tube Left	Welding Part	1
5	Bending Tube Right	Welding Part	1
6	Upper Connection Tube	Assembly Part	1
7	Upper Bending Tube Right	Welding Part	1
8	Upper Bending Tube Left	Welding Part	1
9	Hexagonal Head Bolt	M10×75	54
10	Lock Nut	M10	100
11	Flat Gasket	φ10	210
12	Chin Up Bar	Assembly Part	1
13	Upper Plate	T5	4
14	Pulley Frame Tube Right	Welding Part	1
15	Pulley Frame Tube Left	Welding Part	1
16	Upright Tube	Assembly Part	2
17	Tube with Hole Right	Assembly Part	1
18	Tube with Hole Left	Assembly Part	1
19	Lower Plate	T5*659*150	2
20	Sliding Tube Right	Assembly Part	1
21	Sliding Tube Left	Assembly Part	1
22	Foot Tube Cover	Assembly Part	2
23	End Tube	□40*80*1.5	2
24	Hexagonal Head Bolt	M10×80	14
25	Lower Base	Welding Part	2
26	Upper Base	Welding Part	2
27	Guide Rod	φ25*1850	2
28	Lock Sleeve	φ40*φ25.5*35	2
29	Sliding Sleeve	Assembly Part	2
30	Rubber Pad with Groove	φ60×φ26×45	2
31	Safety Hook Right	Assembly Part	1
32	Safety Hook Left	Assembly Part	1
33	Hexagonal Head Bolt	M10×90	8
34	No Head Inner Hexagonal Bolt	M8*10	2

## PARTS LIST

NO.	DESCRIPTION	NOTE	QTY
35	Pipe	Assembly Part	2
36	Chain + Safety Hook	Assembly Part	3
37	Spring Collar	φ50	6
38	Inner Hexagonal Flat Round Head Bolt	M12×40	2
39	Spring Gasket	φ12	2
40	Flat Gasket	φ12	2
41	Barbell Rod	Assembly Part	1
42	Safety Hook	Standard Part	2
44	Rubber Pad	φ60×φ27×42	4
45	Guide Rod Hollow	φ25*0.8	4
46	Reinforcing Plate	T8*95*50	4
47	Weight Stack	Assembly Part	2
48	Hexagonal Head Bolt	M10×20	8
49	Wire	φ5*2695	1
50	Pulley	φ92	20
51	Pulley Plate	T4	6
52	Hexagonal Head Bolt	M10×45	16
53	Hexagonal Head Bolt	M10×50	4
54	Hexagonal Head Bolt	M10×25	7
55	Weight	Assembly Part	2
56	Wire	Assembly Part	2
57	"-" Shaped Pulley Frame	Welding Part	2
58	Pulley Space Sleeve	Φ20*φ16*φ10.5*20.5	16
59	Pulley	φ50	6
60	Wire	Assembly Part	2
61	Barbell Plate Holder	Assembly Part	6
62	Connection Strap	1956	1
63	Shield Left	T1.2	1
64	Shield Right	T1.2	1
65	Hexagonal Head Bolt	M6×16	10
66	Flat Gasket	φ6	10
67	Hook		4
68	Cross Groove Plate Head Bolt	M4×8	8
69	Lock Nut	M4	8

## PARTS LIST

NO.	DESCRIPTION	NOTE	QTY
70	Hexagonal Head Bolt	M8×20	14
71	Flat Gasket	φ8	14
72	Core Trainer	Assembly Part	1
73	Powder Metallurgy Sleeve	φ33×φ29×φ20×18	2
74	Barbell Bar Cover	Welding Part	1
75	Large Flat Gasket	φ25*φ10*2	1
77	Dip Bar Left	Assembly Part	1
78	Dip Bar Right	Assembly Part	1
79	Barbell Rod Holder Right	Assembly Part	1
80	Barbell Rod Holder Left	Assembly Part	1
81	Barbell Rod Holder Short Left	Assembly Part	1
82	Barbell Rod Holder Short Right	Assembly Part	1
83	Leg Curl Tube	Assembly Part	1
84	Long Bar	Assembly Part	1
85	Ship Rod	Assembly Part	1
86	Hand Belt	Single Ring	2
87	Pull Lift Device	Assembly Part	1
88	T-shaped Pin	φ10*100	1
89	Barbell Clamp Collar	Φ85XΦ50XH49	2
90	Selector Rod	φ25	2
91	Weight Pin	10×60	2
93	Magnetic Pin	φ10×100	2
94	Barbell Rod Spring		2
95	Barbell Rod Gasket		4
96	Lower Plate	T5	2
97	Foot Plate	Assembly Part	1
98	Fixed Spring Rope L-shaped Pin	φ17×250×77L	1
99	Foot Plate Support Weldment	Welding Part	1
100	Short Straight Bar	Assembly Part	1

## Parts and Components List

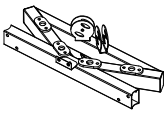

01 Connection Tube  
1PC



02 Upright Frame Left  
1PC



03 Upright Frame Right  
1PC

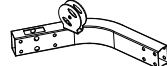

04 Bending Tube Left  
1PC

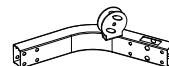

05 Bending Tube Right  
1PC

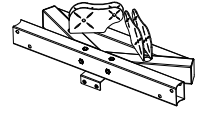

06 Upper Connection  
Tube 1PC

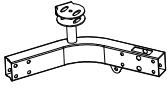

07 Upper Bending Tube  
Right 1PC

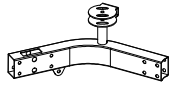

08 Upper Bending Tube  
Left 1PC

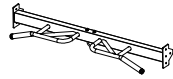

12 Chin Up Bar  
1PC

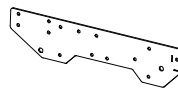

13 Upper Plate  
4PC

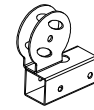

14 Pulley Frame Tube  
Right 1PC



15 Pulley Frame Tube  
Left 1PC

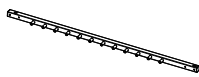

16 Upright Tube  
2PC



17 Tube With Hole Right  
1PC



18 Tube With Hole Left  
1PC

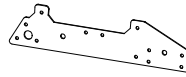

19 Lower Plate  
2PC

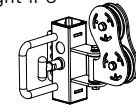

20 Sliding Tube Right  
1PC

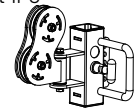

21 Sliding Tube Left  
1PC



22 Foot Tube Cover  
2PC



23 End Tube  
2PC

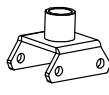

25 Lower Base  
2PC

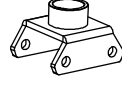

26 Upper Base  
2PC

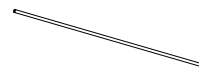

27 Guide Rod  
2PC



28 Lock Sleeve  
2PC

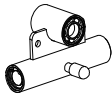

29 Sliding Sleeve  
2PC



30 Rubber Pad With  
Groove 2PC

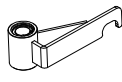

31 Safety Hook Right  
1PC

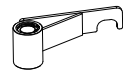

32 Safety Hook Left  
1PC

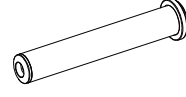

35 Pipe 2PC

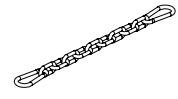

36 Chain + Safety Hook  
3PC



37 Spring Collar 6PC



41 Barbell Rod  
1PC



42 2PC



44 Rubber Pad  
4PC



45 Guide Rod Hollow  
4PC



46 Reinforcing Plate  
4PC

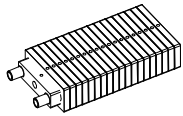

47 Weight Stack  
2PC

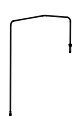

49 Wire  $\phi 5 \times 2745$   
2PC



50 Pulley  $\phi 95$   
20PC

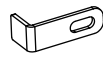

51 Pulley Plate  
6PC

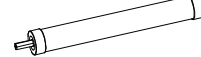

55 Weight  
2PC



56 Wire  
1PC

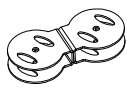

57 1/2" Shaped Pulley  
Frame 3PC



58 Pulley Spacers Sleeve  
16PC



59  $\phi 50$  Pulley  
6PC

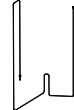

60 Wire  
2PC

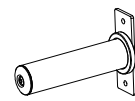

61 Barbell Plate Holder  
6PC



62 Connection Strap  
1PC

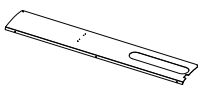

63 Shield Left  
1PC

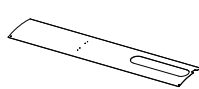

63 Shield Right  
1PC



67 Hook  
4PC

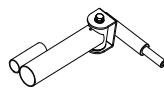

72 Core Trainer  
1PC



73 Power Metallurgy  
Sleeve 4PC



74 Barbell Rod Cover  
1PC

## Parts and Components List

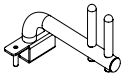

77 Dip Bar Left  
1PC

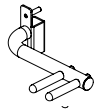

78 Dip Bar Right  
1PC

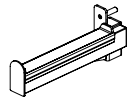

79 Barbell Rod Holder  
Right 1PC

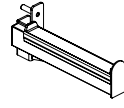

80 Barbell Rod Holder  
Left 1PC



81 Barbell Rod Holder  
Short Left 1PC



82 Barbell Rod Holder  
Short Right 1PC

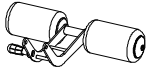

83 Leg Curl Tube  
1PC



84 Long Bar  
1PC



85 Ship Rod  
1PC



86 Hand Belt  
2PC

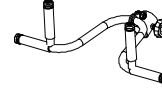

87 Pull Lift Device  
1PC



88 T Shape Pin  
1PC



89 Barbell Clamp Collar  
2PC



90 Selector Rod  
2PC



91 Weight Pin  
2PC



93 Magnetic Pin  
2PC



94 Barbell Rod Spring  
2PC



95 Barbell Rod Gasket  
4PC

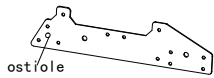

96 3058S Lower Plate  
2PC



97 3075 Foot Plate  
1PC



98 Fixed Spring Rope  
L-shaped Pin  
1PC

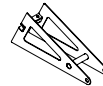

99 3075 Foot Plate  
Support Weldment  
1PC

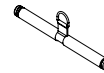

100 Short Straight Bar  
1PC

## Screw Tool Diagram

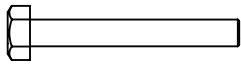

M10\*75 54PCS (9)

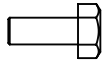

M10\*25 7PCS (54)



M10\*20 8PCS (48)

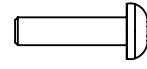

M12\*40 2PCS (38)



M8\*10 2PCS (34)



M8\*20 14PCS (70)



$\phi$  25\*  $\phi$  10.5\*T2.0  
1PCS (75)



M4\*8 8PCS (8)

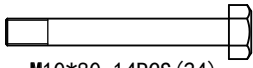

M10\*80 14PCS (24)



M6\*16 10PCS (65)



$\phi$  6 10PCS (66)



$\phi$  12 2PCS (39)



$\phi$  12 2PCS (40)



$\phi$  8 14PCS (71)



M4 8PCS (69)



M10 100PCS (10)

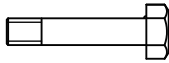

M10\*50 4PCS (53)

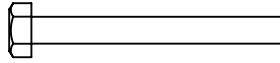

M10\*90 8PCS (33)



$\phi$  10 210PCS (11)

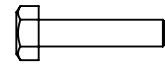

M10\*45 16PCS (52)

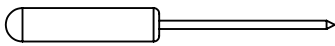

1PCS

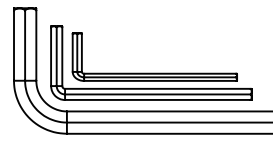

3、4、8MM 1PCS

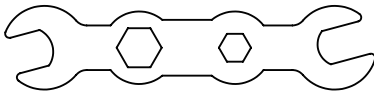

1PCS

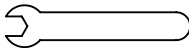

M4 1PCS



17-19 2PCS



## ASSEMBLY STEP 1

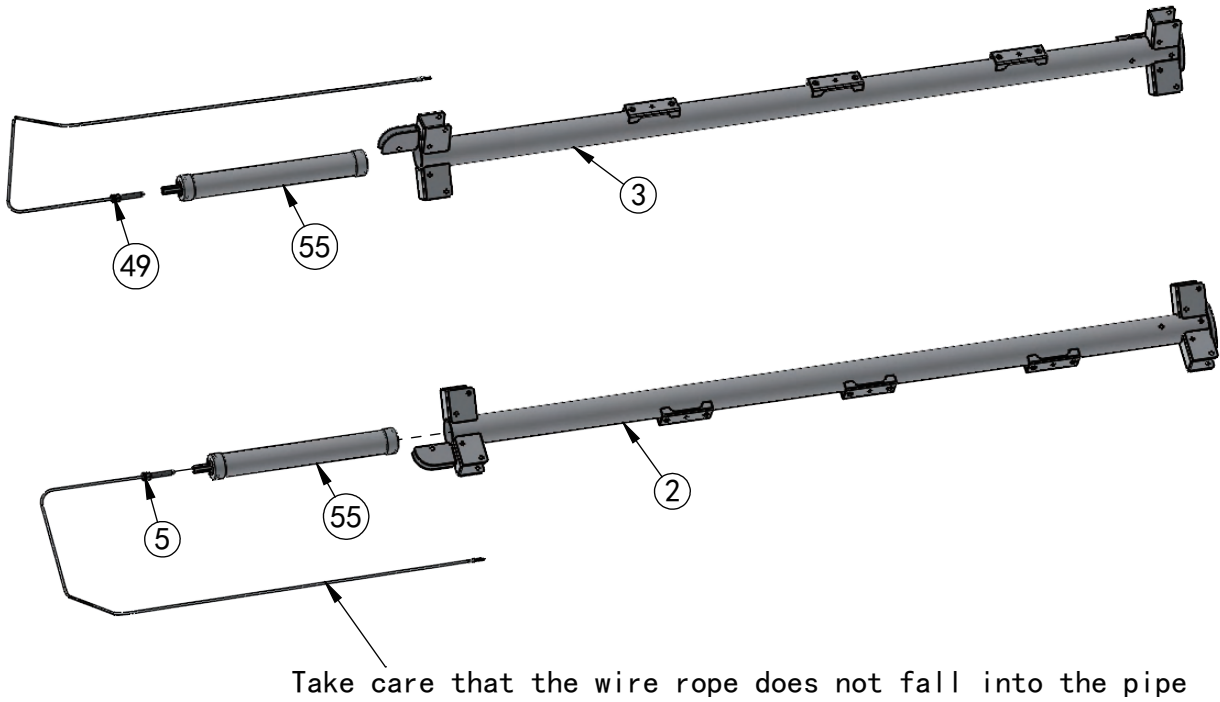

NO.	DESCRIPTION	NOTE	QTY
2	Upright Frame Left	Assembly Part	1
3	Upright Frame Right	Assembly Part	1
49	Wire	$\phi 5 * 2695$	1
55	Weight	Assembly Part	2

## ASSEMBLY STEP 2

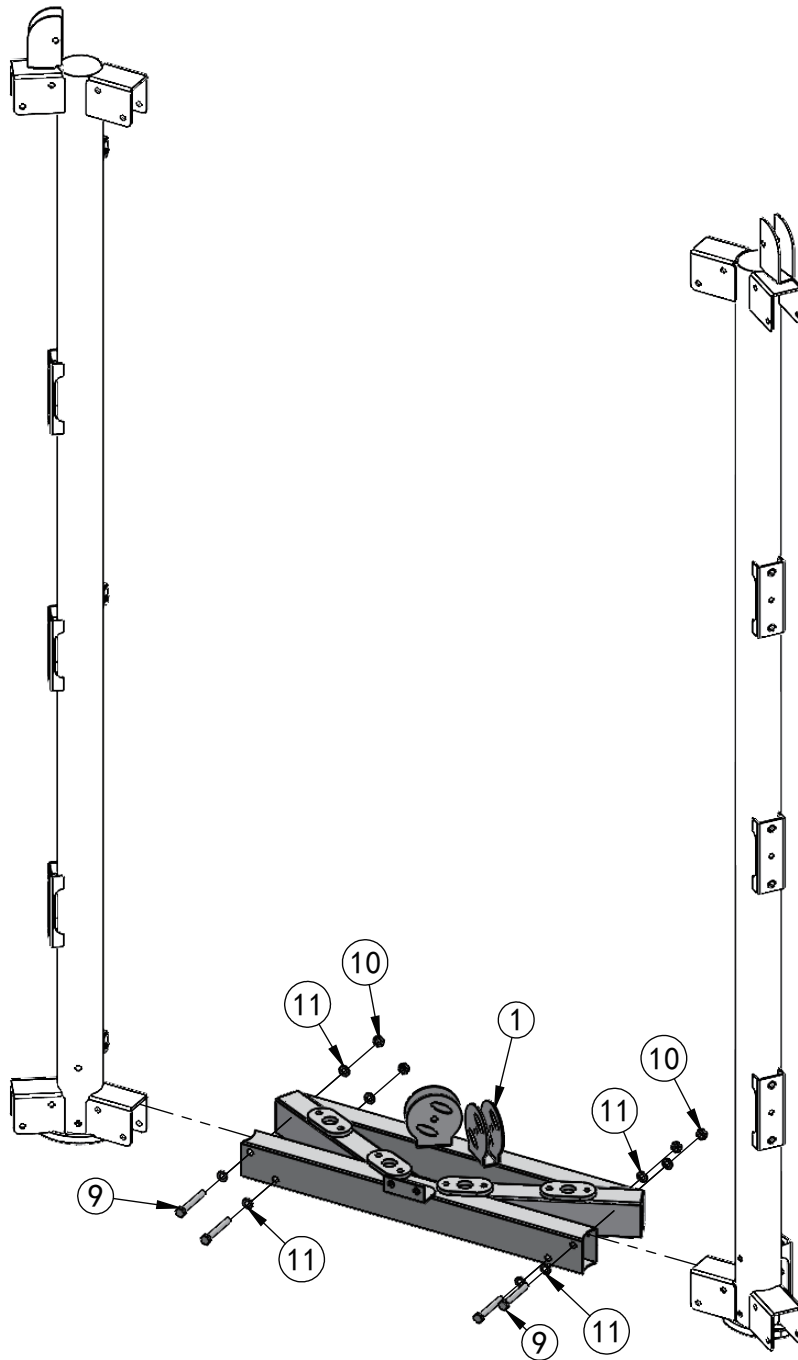

NO.	DESCRIPTION	NOTE	QTY
1	Connection Tube	Assembly Part	1
9	Hexagonal Head Bolt	M10×75	4
10	Lock Nut	M10	4
11	Flat Gasket	φ10	8

## ASSEMBLY STEP 3

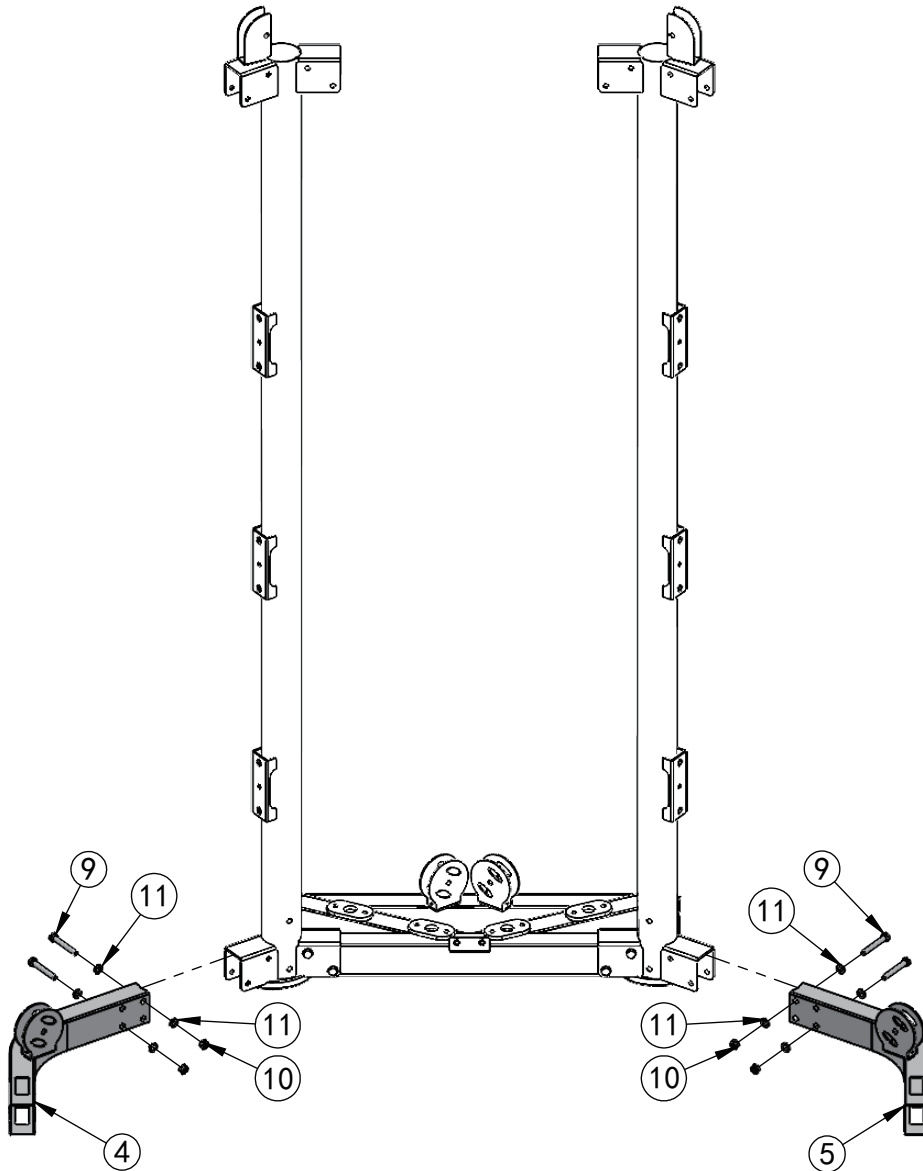

NO.	DESCRIPTION	NOTE	QTY
4	Bending Tube Left	Welding Part	1
5	Bending Tube Right	Welding Part	1
9	Hexagonal Head Bolt	M10×75	4
10	Lock Nut	M10	4
11	Flat Gasket	φ10	8

## ASSEMBLY STEP 4

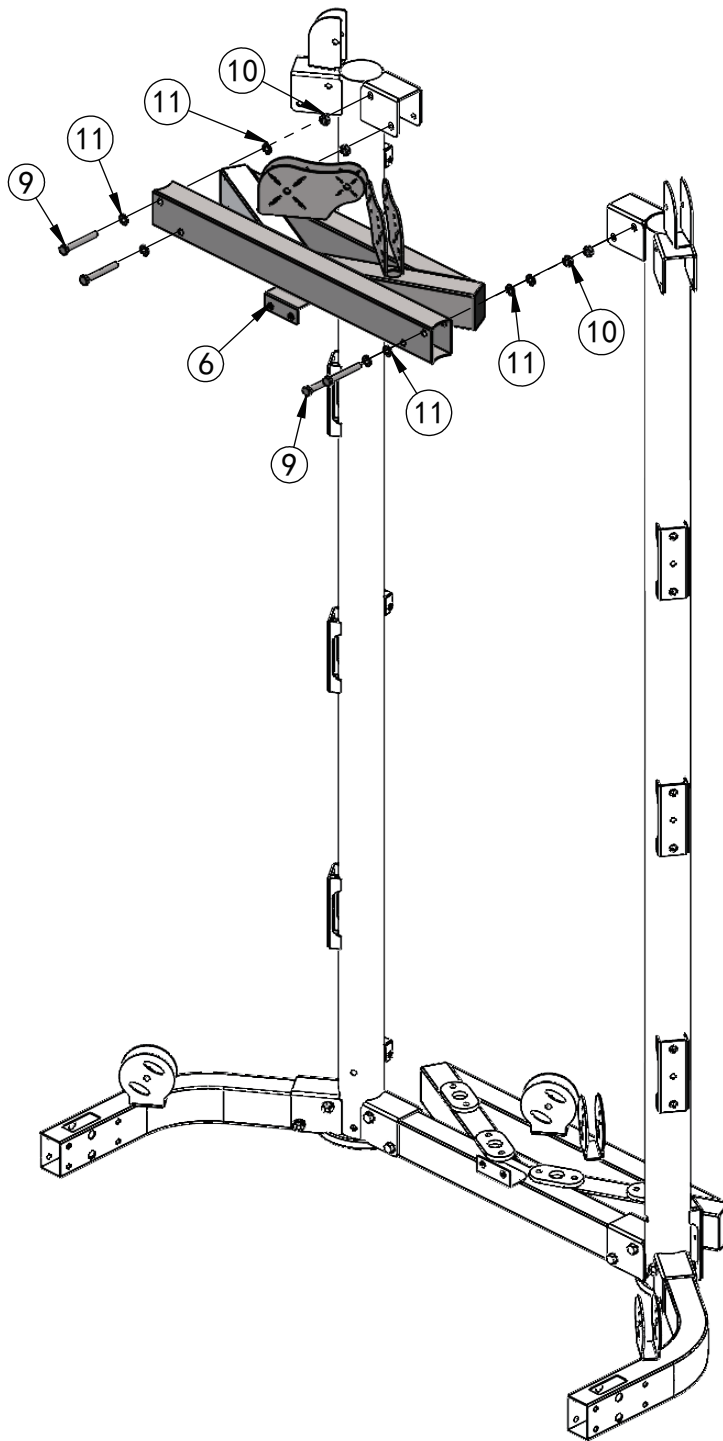

NO.	DESCRIPTION	NOTE	QTY
6	Upper Connection Tube	Assembly Part	1
9	Hexagonal Head Bolt	M10×75	4
10	Lock Nut	M10	4
11	Flat Gasket	φ10	8

## ASSEMBLY STEP 5

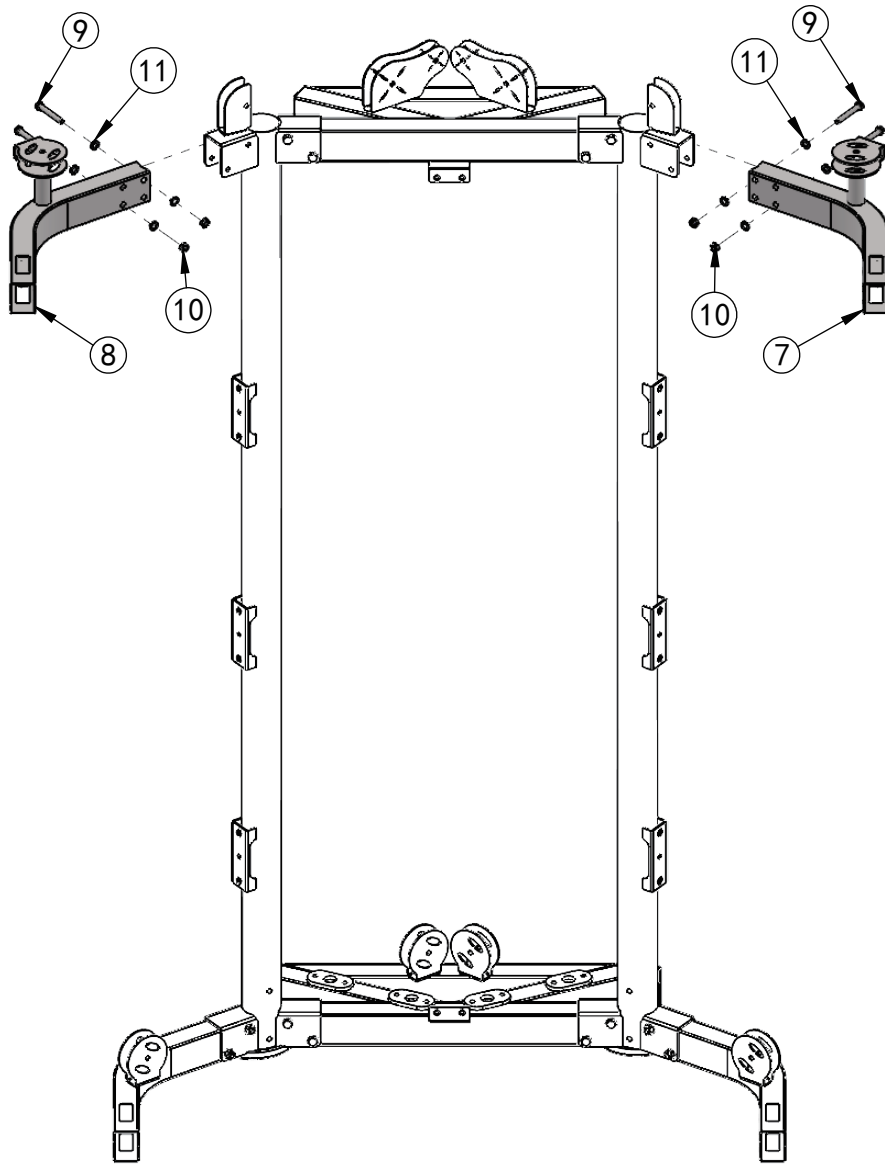

NO.	DESCRIPTION	NOTE	QTY
7	Upper Bending Tube Right	Welding Part	1
8	Upper Bending Tube Left	Welding Part	1
9	Hexagonal Head Bolt	M10×75	4
10	Lock Nut	M10	4
11	Flat Gasket	φ10	8

## ASSEMBLY STEP 6

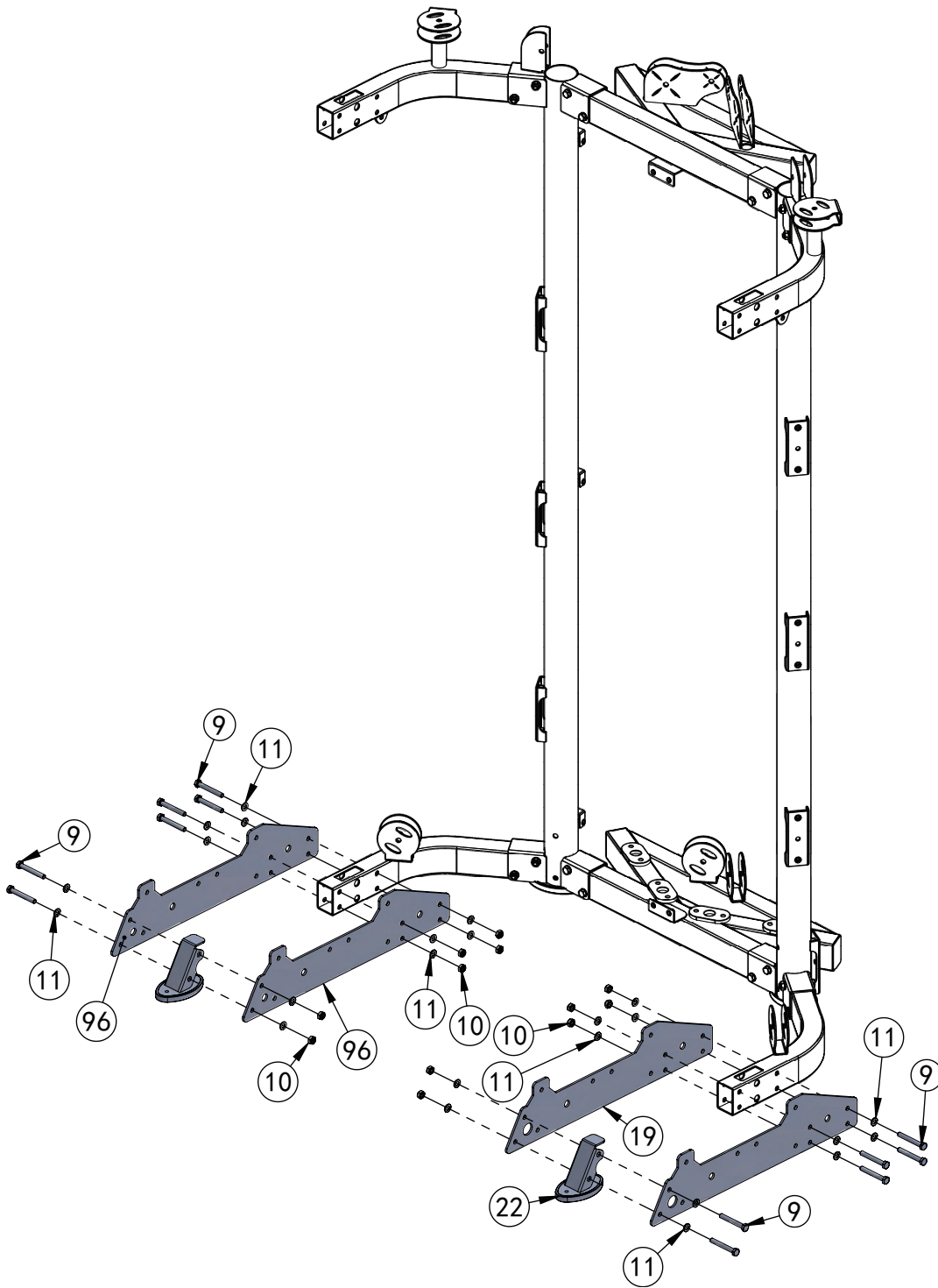

NO.	DESCRIPTION	NOTE	QTY
9	Hexagonal Head Bolt	M10×75	12
10	Lock Nut	M10	12
11	Flat Gasket	φ10	24
19	Lower Plate	T5*659*150	2
22	Foot Tube Cover	Assembly Part	2
96	Lower Plate	T5	2

## ASSEMBLY STEP 7

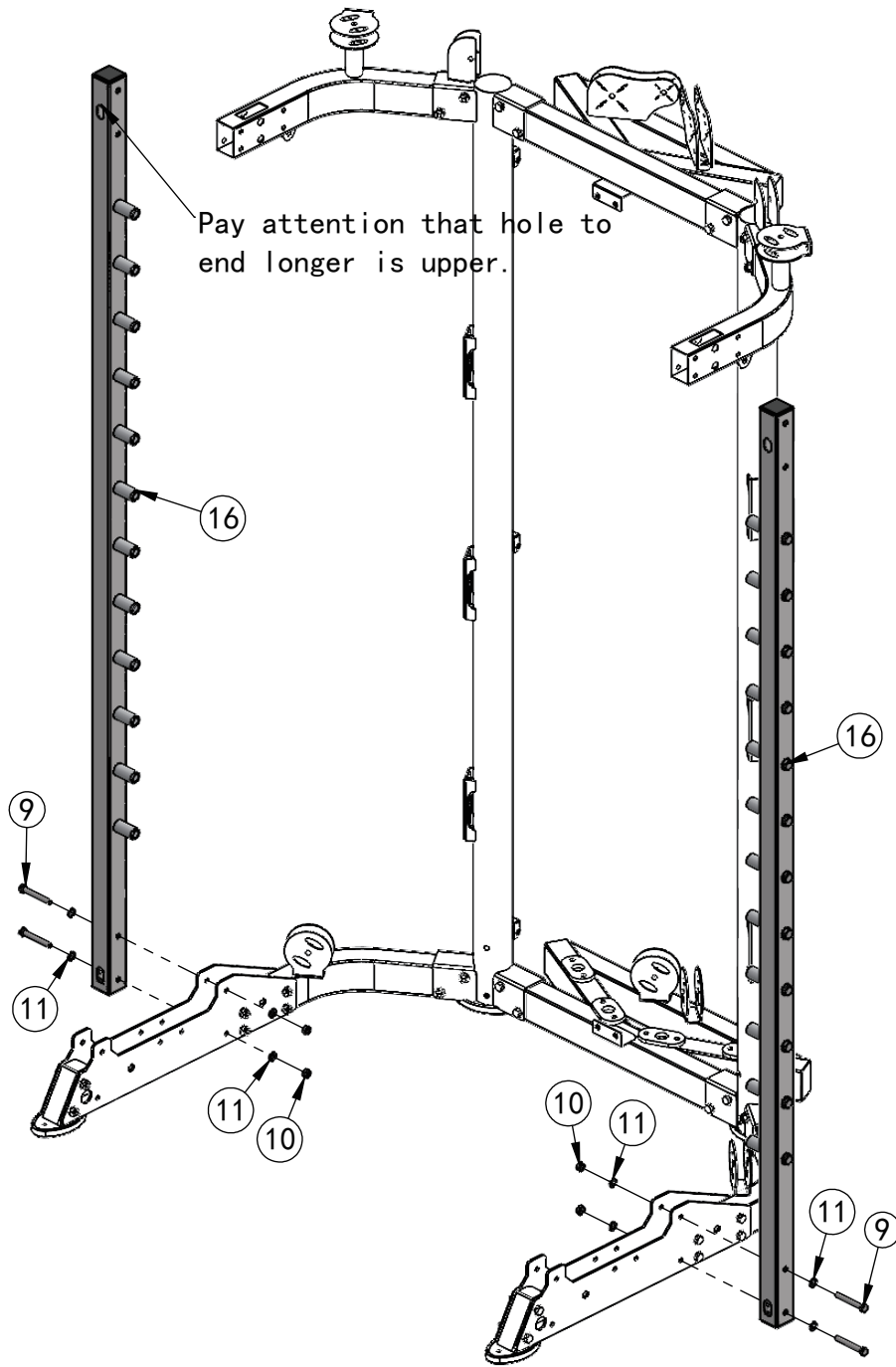

NO.	DESCRIPTION	NOTE	QTY
9	Hexagonal Head Bolt	M10×75	4
10	Lock Nut	M10	4
11	Flat Gasket	φ10	8
16	Upright Tube	Assembly Part	2

## ASSEMBLY STEP 8

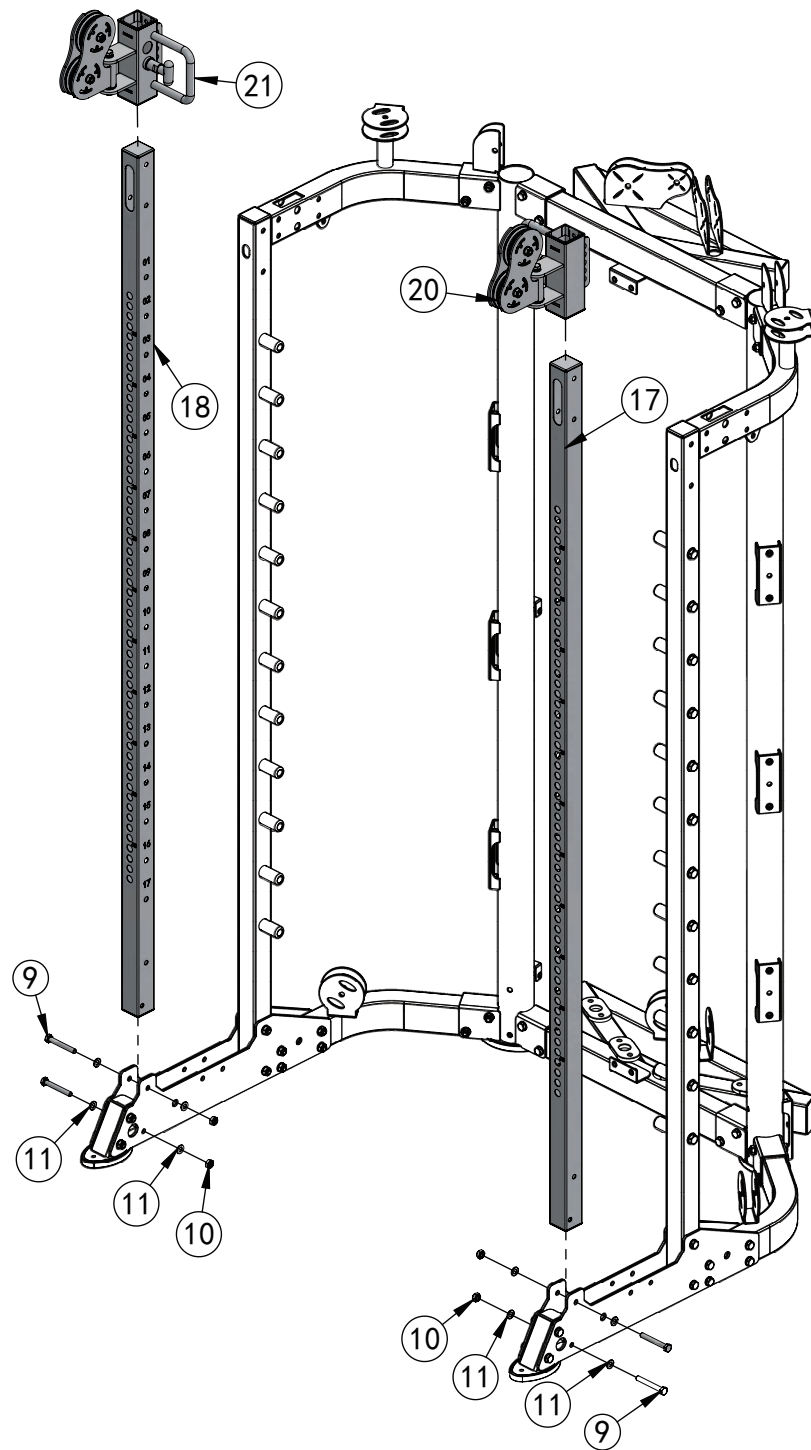

NO.	DESCRIPTION	NOTE	QTY
9	Hexagonal Head Bolt	M10×75	4
10	Lock Nut	M10	4
11	Flat Gasket	φ10	8
17	Tube with Hole Right	Assembly Part	1
18	Tube with Hole Left	Assembly Part	1
20	Sliding Tube Right	Assembly Part	1
21	Sliding Tube Left	Assembly Part	1



## ASSEMBLY STEP 9

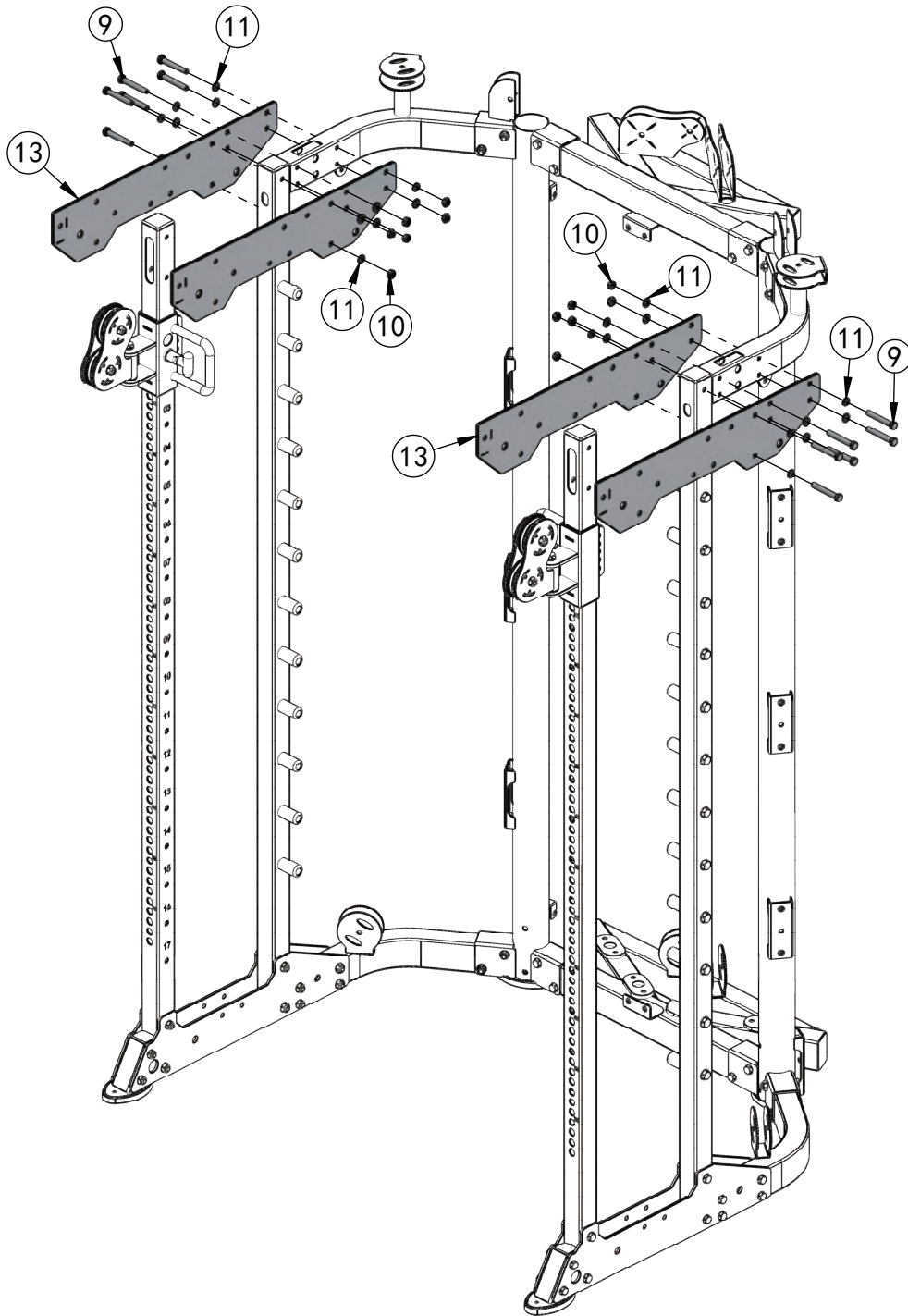

NO.	DESCRIPTION	NOTE	QTY
9	Hexagonal Head Bolt	M10×75	12
10	Lock Nut	M10	12
11	Flat Gasket	φ10	24
13	Upper Plate	T5	4

## ASSEMBLY STEP 10

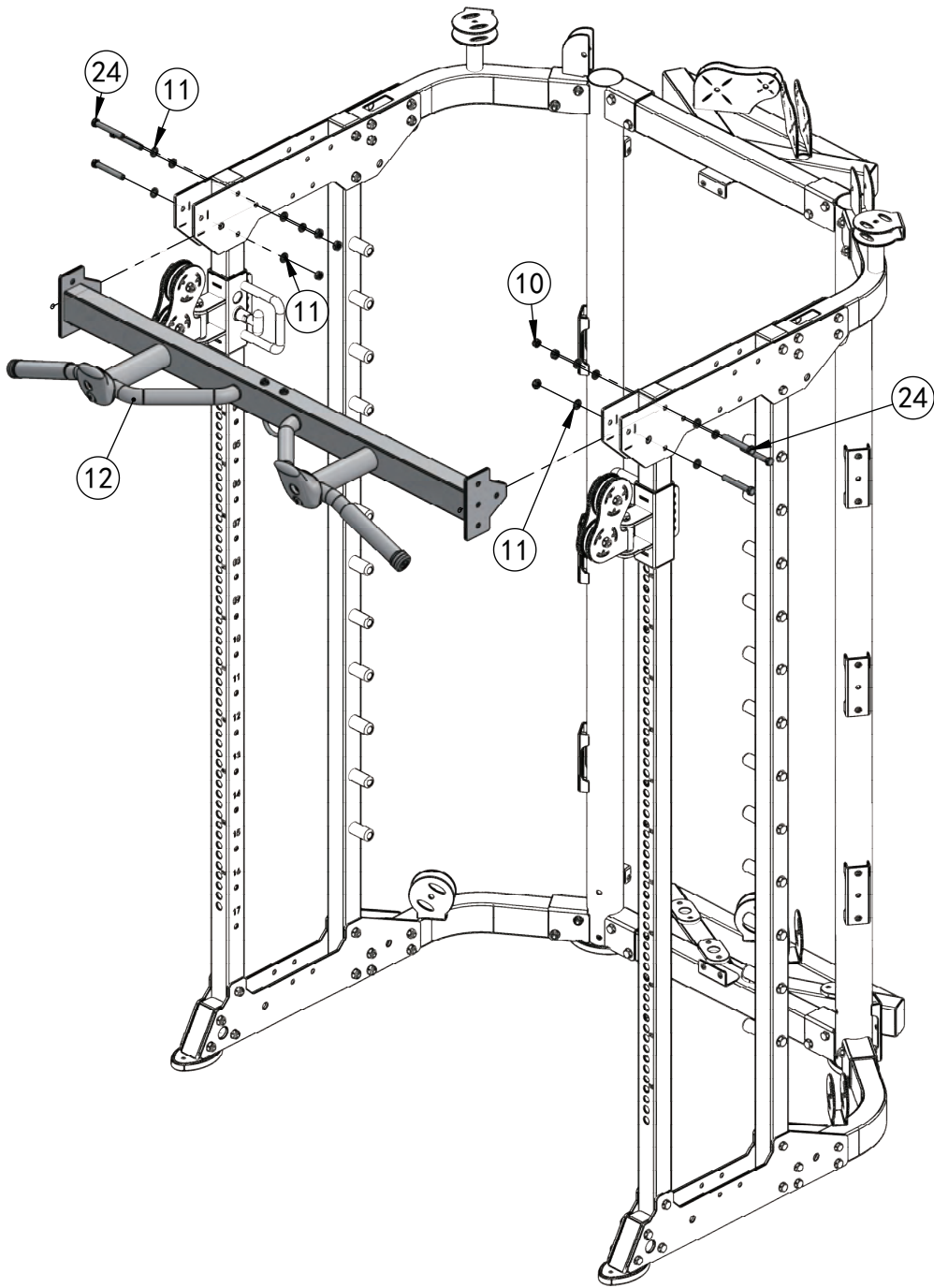

NO.	DESCRIPTION	NOTE	QTY
10	Lock Nut	M10	6
11	Flat Gasket	φ10	12
12	Chin Up Bar	Assembly Part	1
24	Hexagonal Head Bolt	M10×80	6

## ASSEMBLY STEP 11

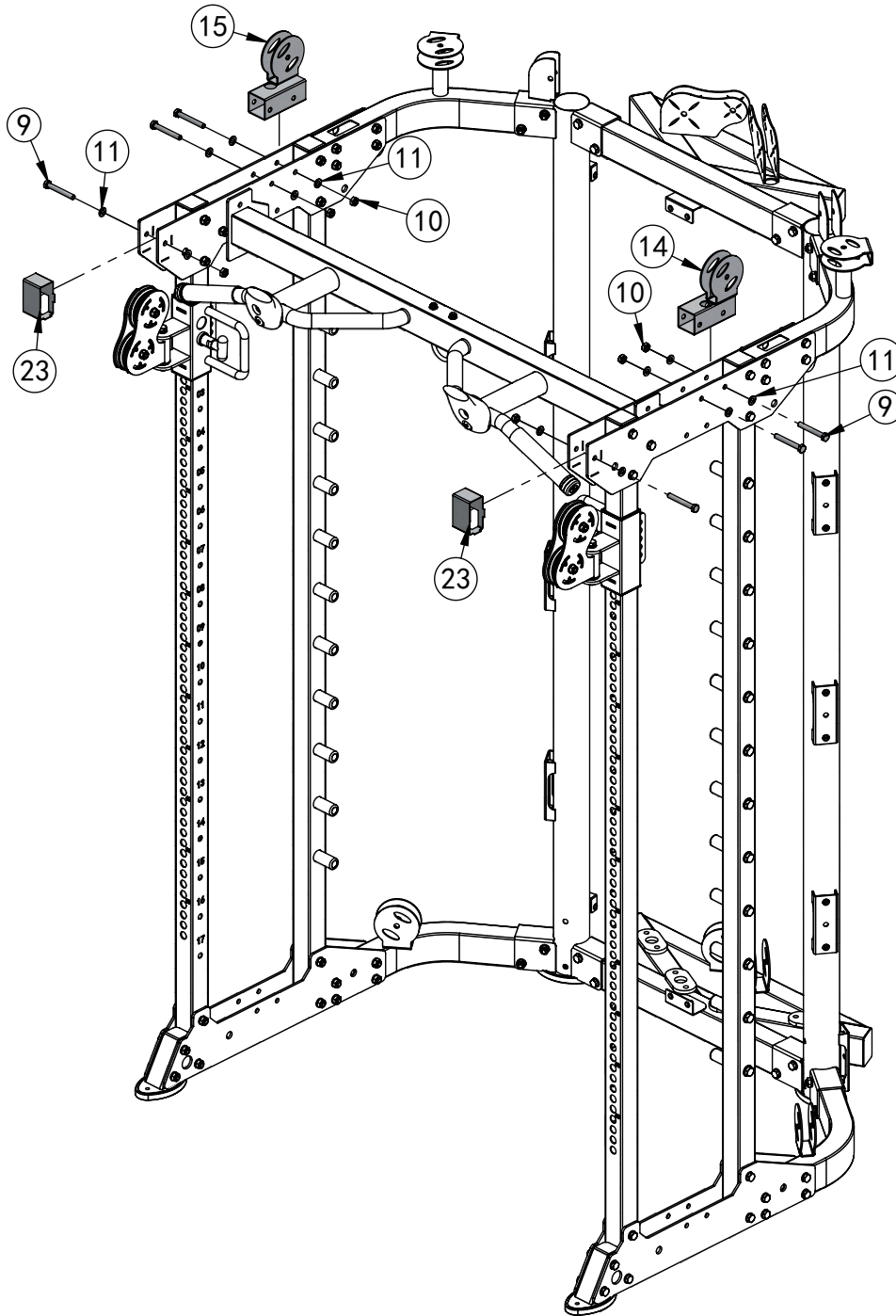

NO.	DESCRIPTION	NOTE	QTY
9	Hexagonal Head Bolt	M10×75	6
10	Lock Nut	M10	6
11	Flat Gasket	φ10	12
14	Pulley Frame Tube Right	Welding Part	1
15	Pulley Frame Tube Left	Welding Part	1
23	End Tube	□40*80*1.5	2

## ASSEMBLY STEP 12

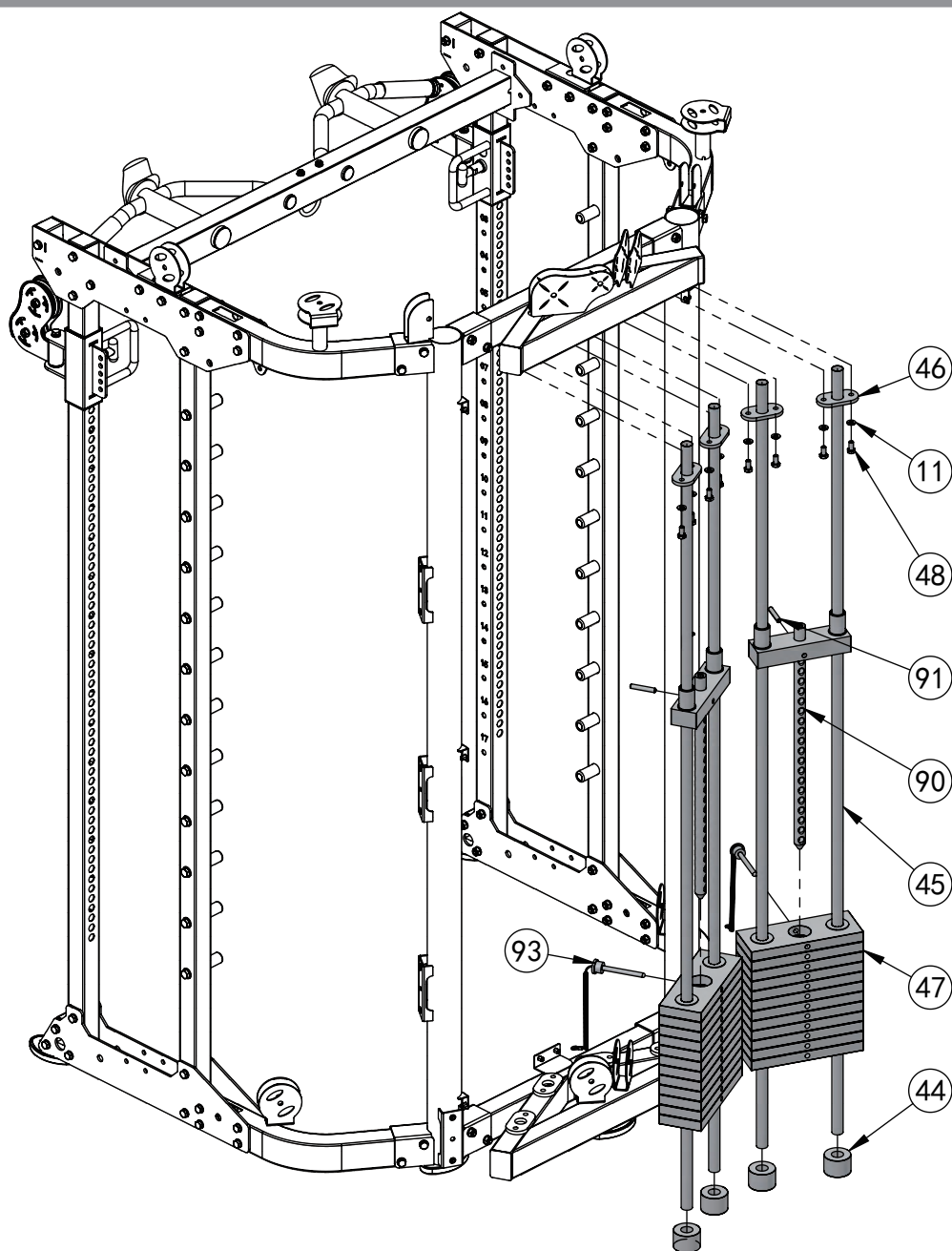

NO.	DESCRIPTION	NOTE	QTY
11	Flat Gasket	φ10	8
44	Rubber Pad	φ60×φ27×42	4
45	Guide Rod Hollow	φ25*0.8	4
46	Reinforcing Plate	T8*95*50	4
47	Weight Stack	Assembly Part	2
48	Hexagonal Head Bolt	M10×20	8
90	Selector Rod	φ25	2
91	Weight Pin	10×60	2
93	Magnetic Pin	φ10×100	2

## ASSEMBLY STEP 13

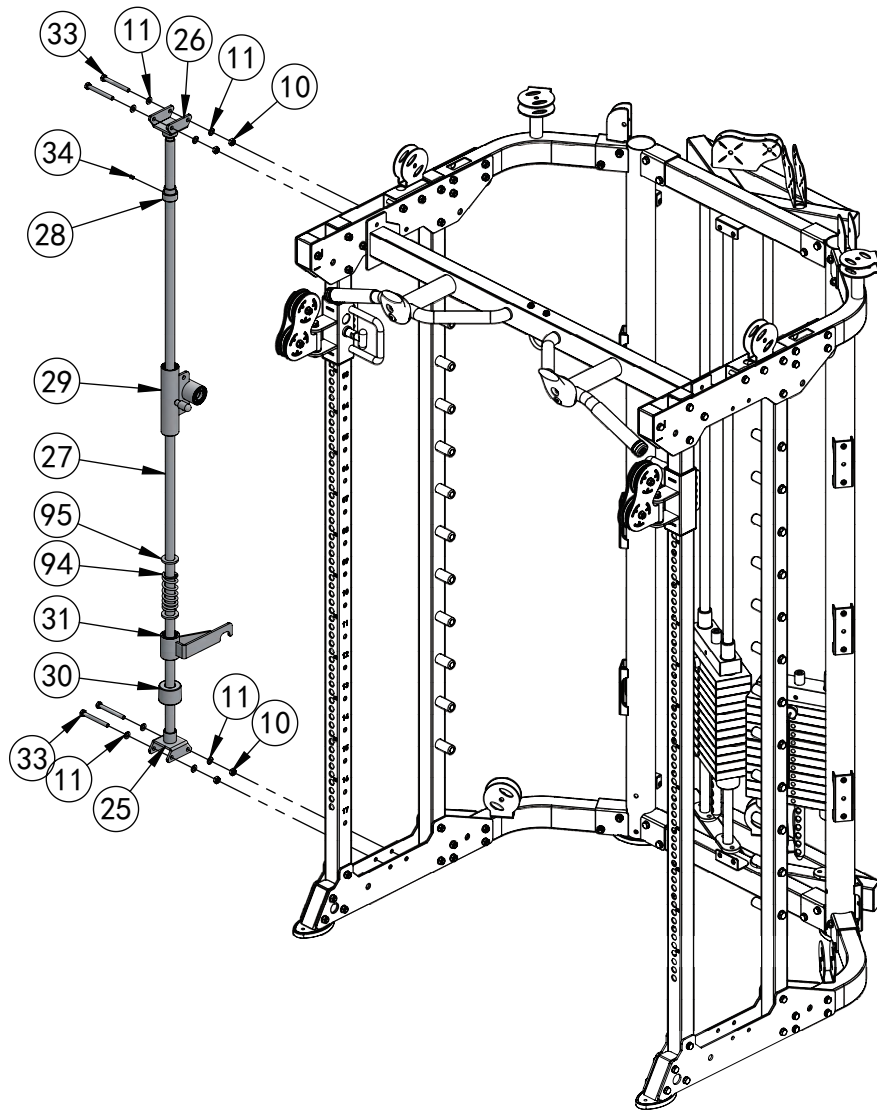

NO.	DESCRIPTION	NOTE	QTY
10	Lock Nut	M10	4
11	Flat Gasket	φ10	8
25	Lower Base	Welding Part	1
26	Upper Base	Welding Part	1
27	Guide Rod	φ25*1850	1
28	Lock Sleeve	φ40*φ25.5*35	1
29	Sliding Sleeve	Assembly Part	1
30	Rubber Pad with Groove	φ60×φ26×45	1
31	Safety Hook Right	Assembly Part	1
33	Hexagonal Head Bolt	M10×90	4
34	No Head Inner Hexagonal Bolt	M8*10	1
94	Barbell Rod Spring		1
95	Barbell Rod Gasket		2

## ASSEMBLY STEP 14

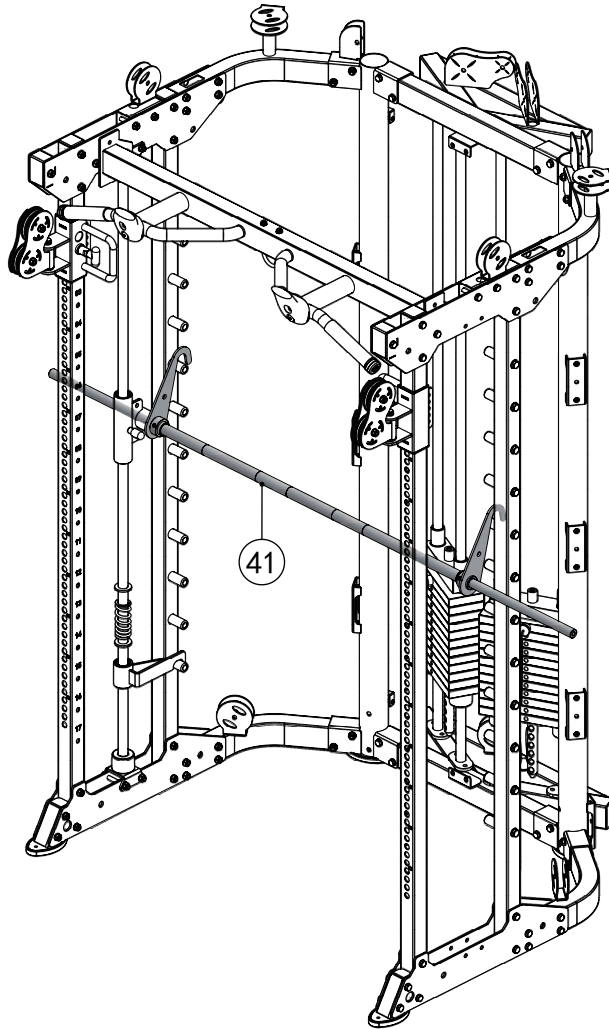

NO.  
41

DESCRIPTION  
Barbell Rod

NOTE  
Assembly Part

QTY  
1

## ASSEMBLY STEP 15

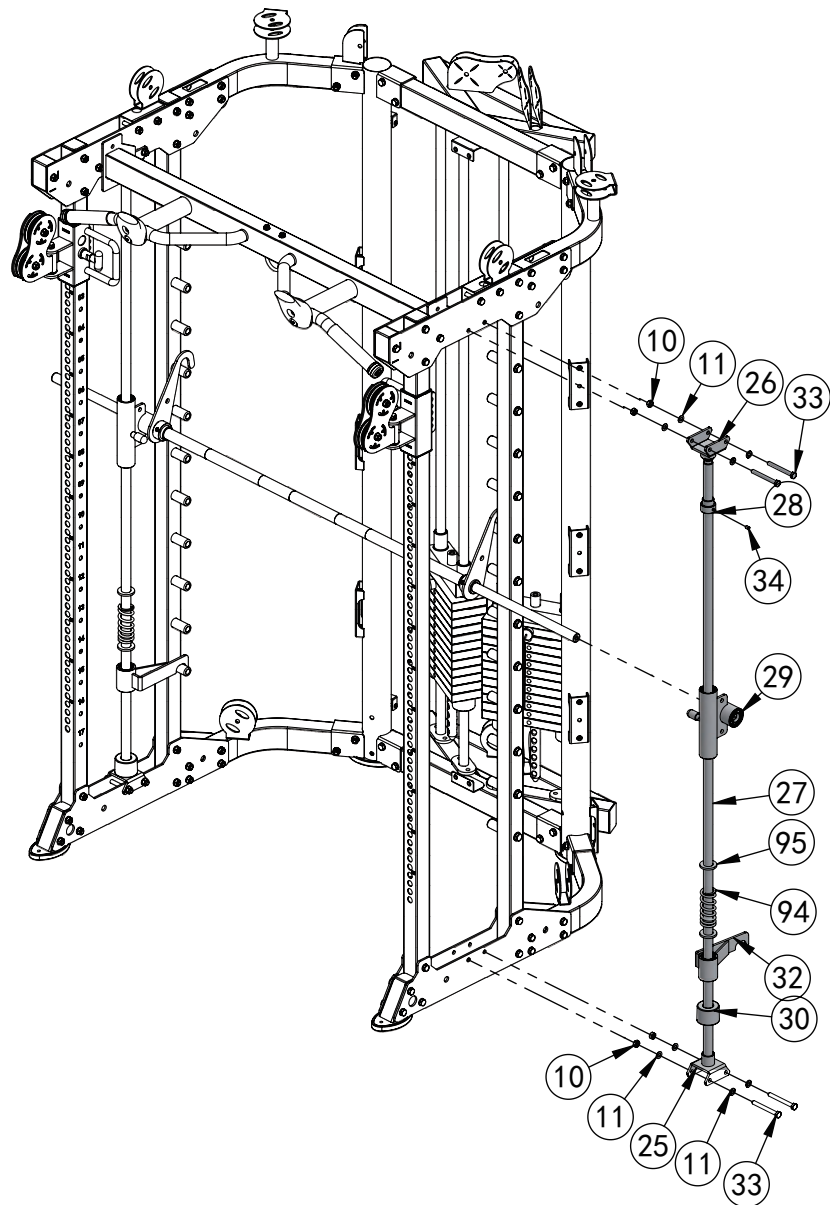

NO.	DESCRIPTION	NOTE	QTY
10	Lock Nut	M10	4
11	Flat Gasket	φ10	8
25	Lower Base	Welding Part	1
26	Upper Base	Welding Part	1
27	Guide Rod	φ25*1850	1
28	Lock Sleeve	φ40*φ25.5*35	1
29	Sliding Sleeve	Assembly Part	1
30	Rubber Pad with Groove	φ60×φ26×45	1
32	Safety Hook Left	Assembly Part	1
33	Hexagonal Head Bolt	M10×90	4
34	No Head Inner Hexagonal Bolt	M8*10	1
94	Barbell Rod Spring		1
95	Barbell Rod Gasket		2

## ASSEMBLY STEP 16

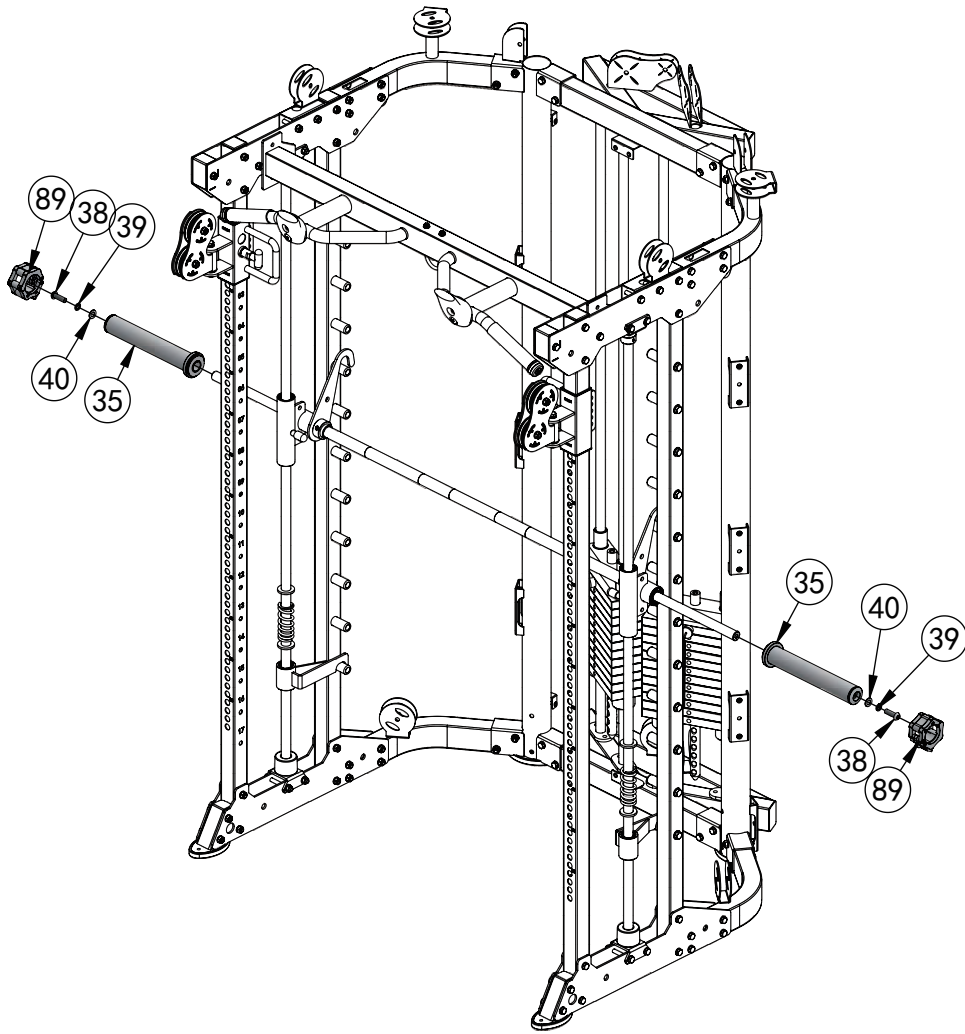

NO.	DESCRIPTION	NOTE	QTY
35	Pipe	Assembly Part	2
38	Inner Hexagonal Flat Round Head Bolt	M12×40	2
39	Spring Gasket	φ12	2
40	Flat Gasket	φ12	2
89	Barbell Clamp Collar	Φ85XΦ50XH49	2



## ASSEMBLY STEP 17

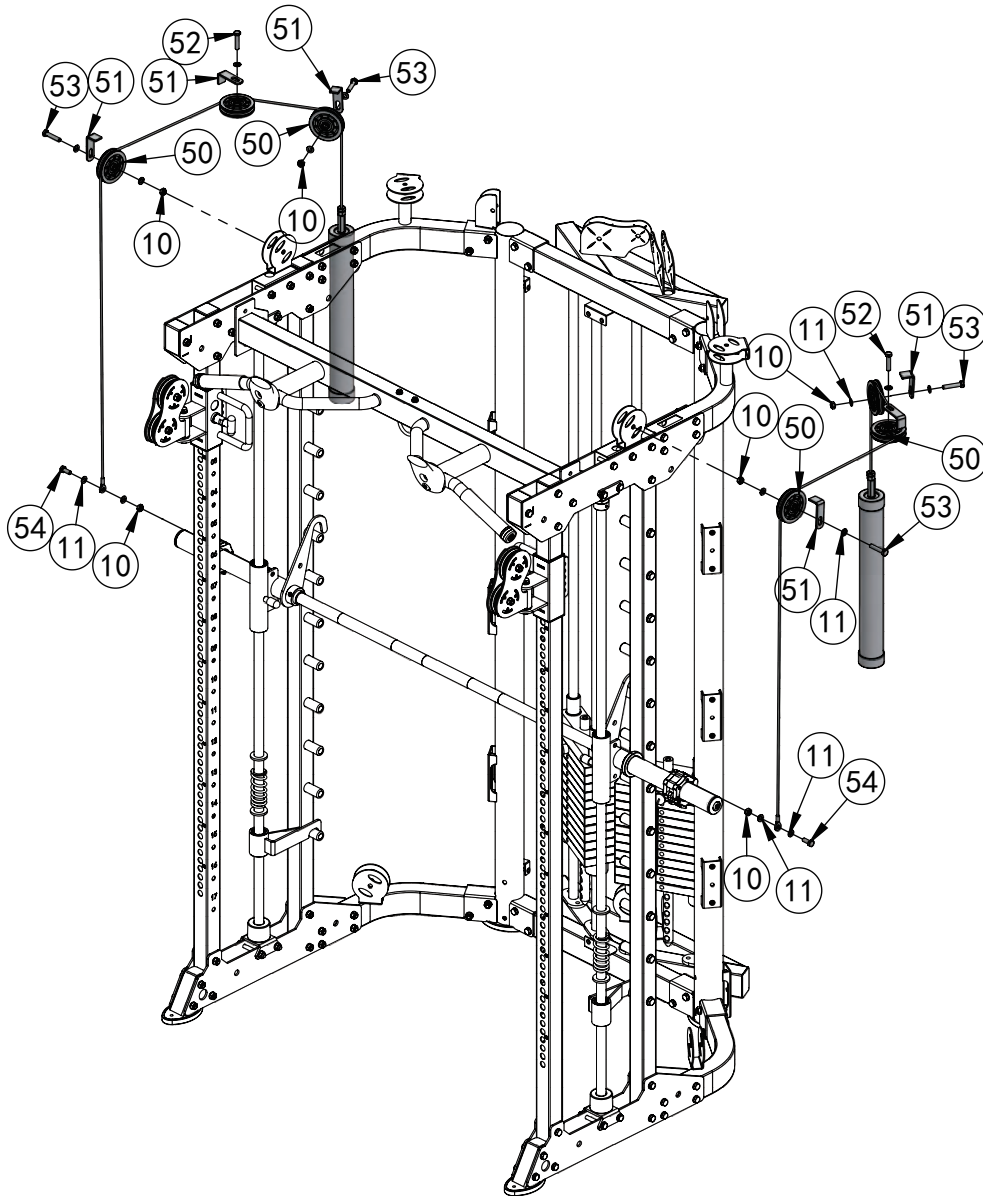

NO.	DESCRIPTION	NOTE	QTY
10	Lock Nut	M10	6
11	Flat Gasket	φ10	14
50	Pulley	φ92	6
51	Pulley Plate	T4	6
52	Hexagonal Head Bolt	M10×45	2
53	Hexagonal Head Bolt	M10×50	4
54	Hexagonal Head Bolt	M10×25	2

# ASSEMBLY DRAWING

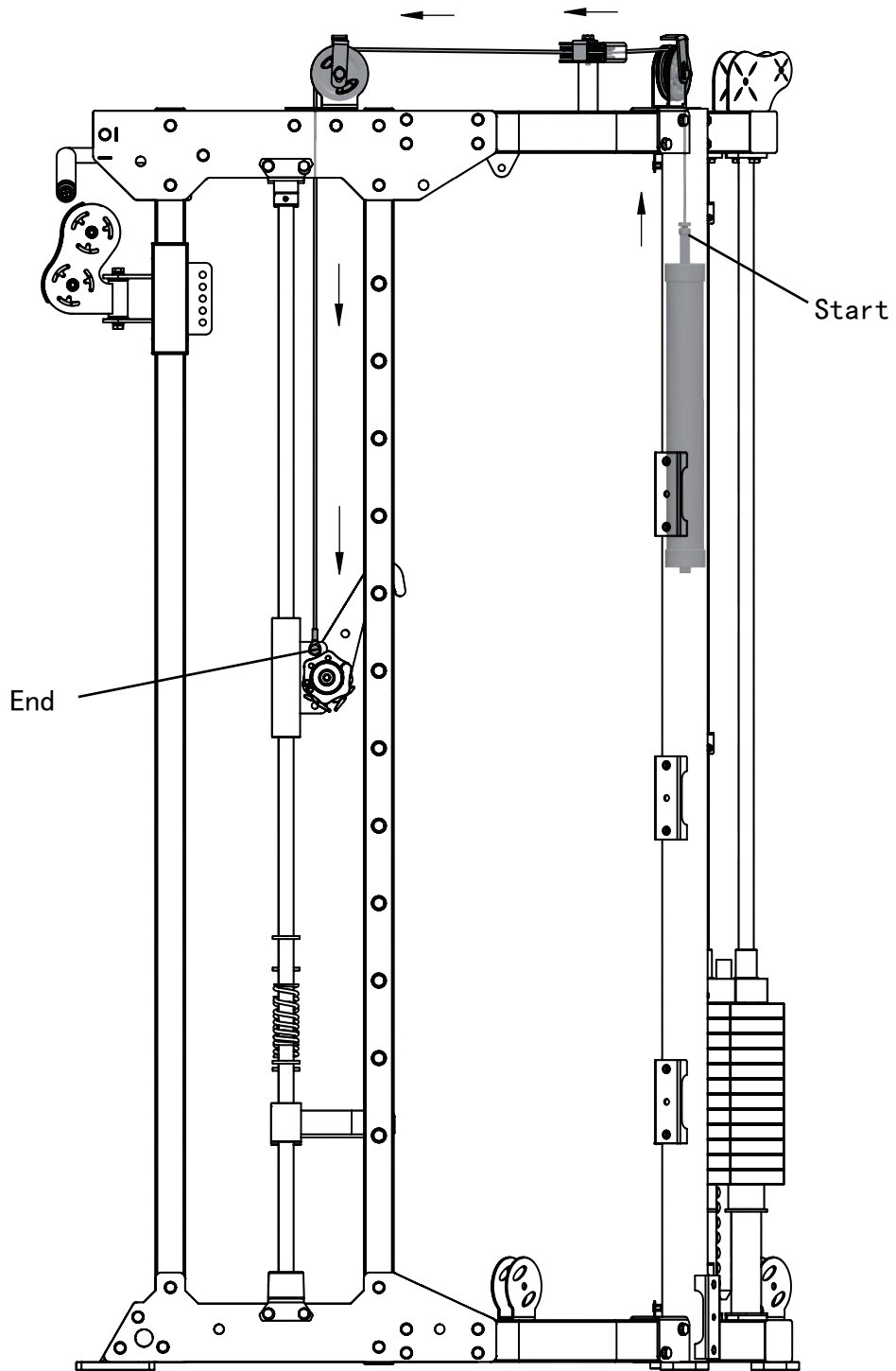

## ASSEMBLY STEP 18

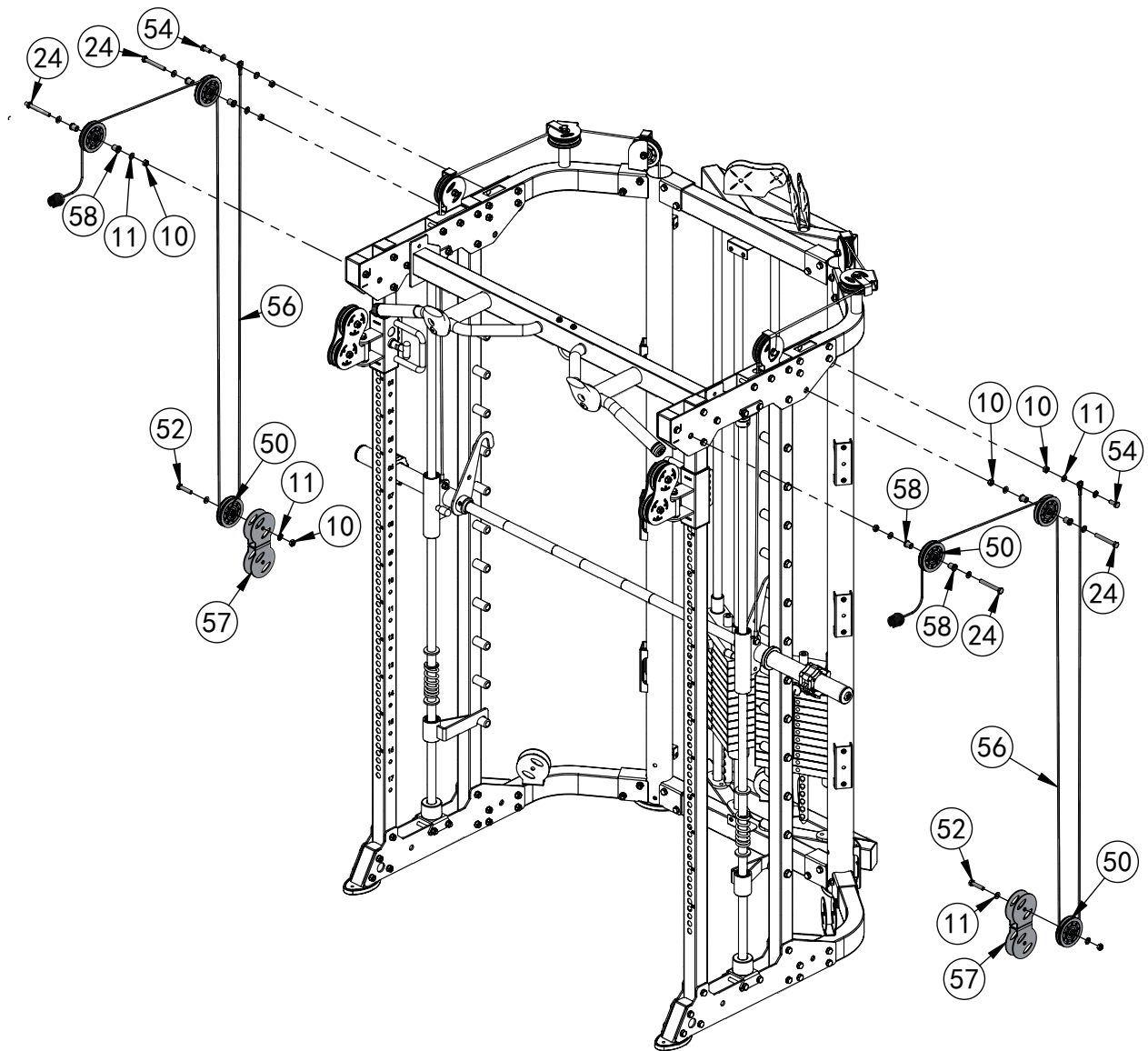

NO.	DESCRIPTION	NOTE	QTY
10	Lock Nut	M10	8
11	Flat Gasket	φ10	16
24	Hexagonal Head Bolt	M10×80	4
50	Pulley	φ92	6
52	Hexagonal Head Bolt	M10×45	2
54	Hexagonal Head Bolt	M10×25	2
56	Wire	Assembly Part	2
57	"-" Shaped Pulley Frame	Welding Part	2
58	Pulley Space Sleeve	Φ20*φ16*φ10.5*20.5	8

# ASSEMBLY DRAWING

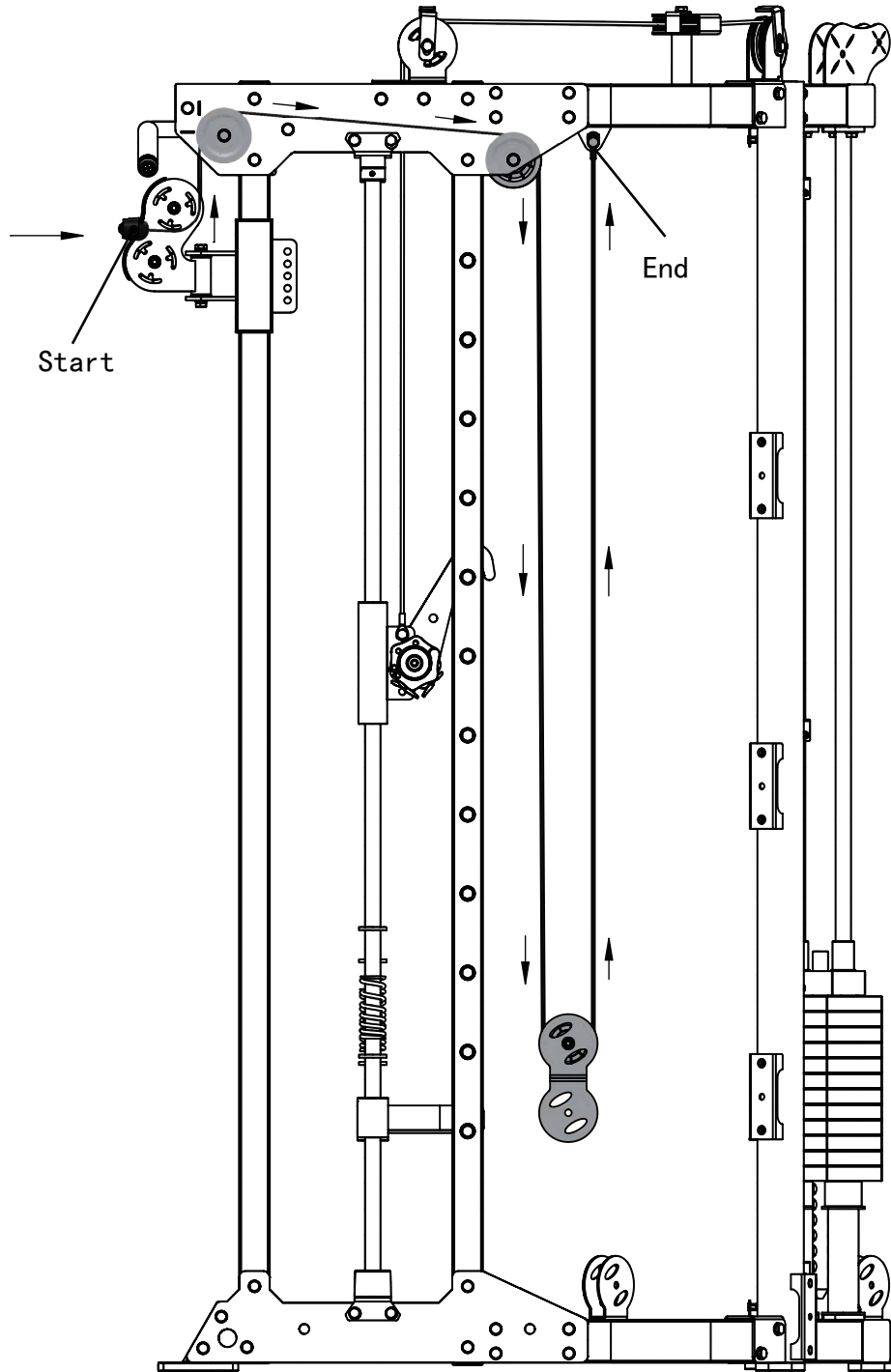

## ASSEMBLY STEP 19

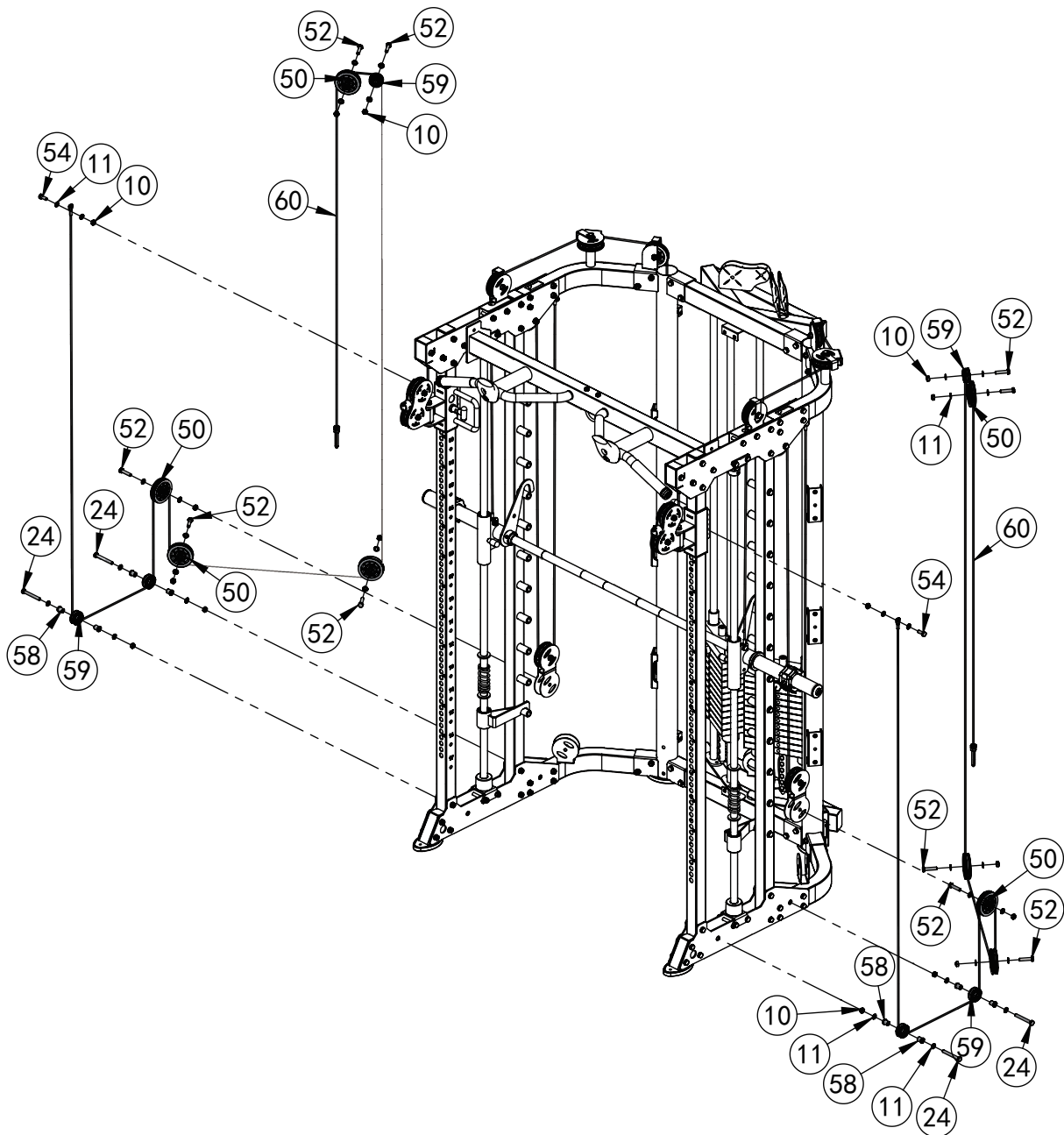

NO.	DESCRIPTION	NOTE	QTY
10	Lock Nut	M10	16
11	Flat Gasket	φ10	32
24	Hexagonal Head Bolt	M10×80	4
50	Pulley	φ92	8
52	Hexagonal Head Bolt	M10×45	10
54	Hexagonal Head Bolt	M10×25	2
58	Pulley Space Sleeve	Φ20*φ16*φ10.5*20.5	8
59	Pulley	φ50	6
60	Wire	Assembly Part	2

# ASSEMBLY DRAWING

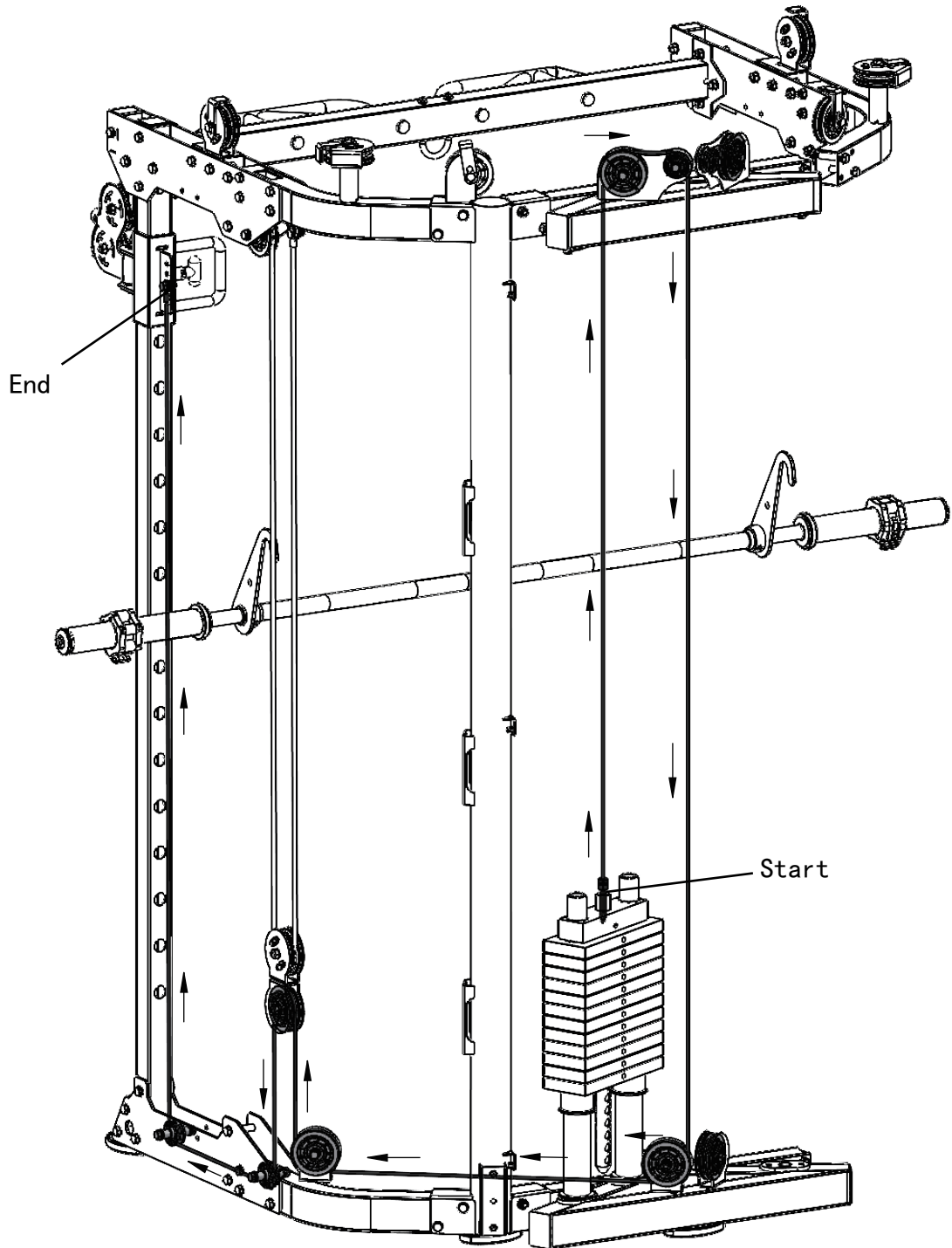

## ASSEMBLY STEP 20

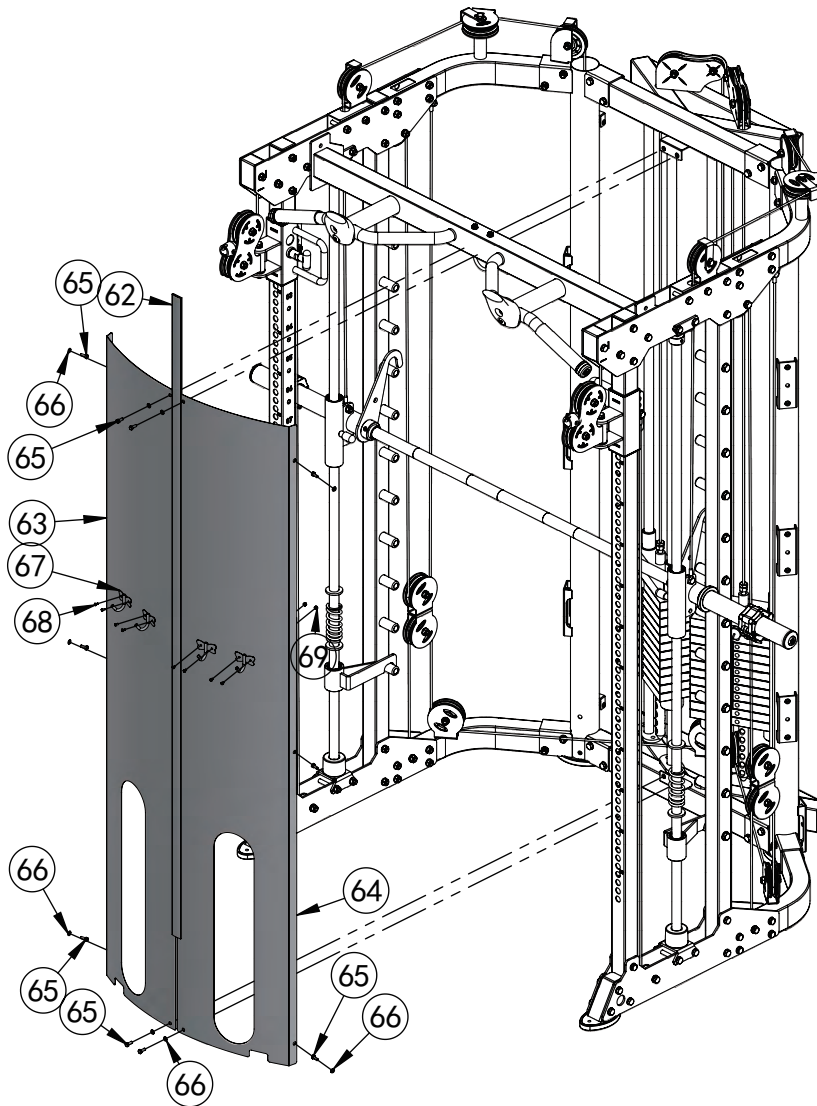

NO.	DESCRIPTION	NOTE	QTY
62	Connection Strap	1956	1
63	Shield Left	T1.2	1
64	Shield Right	T1.2	1
65	Hexagonal Head Bolt	M6×16	10
66	Flat Gasket	φ6	10
67	Hook		4
68	Cross Groove Plate Head Bolt	M4×8	8
69	Lock Nut	M4	8

## ASSEMBLY STEP 21

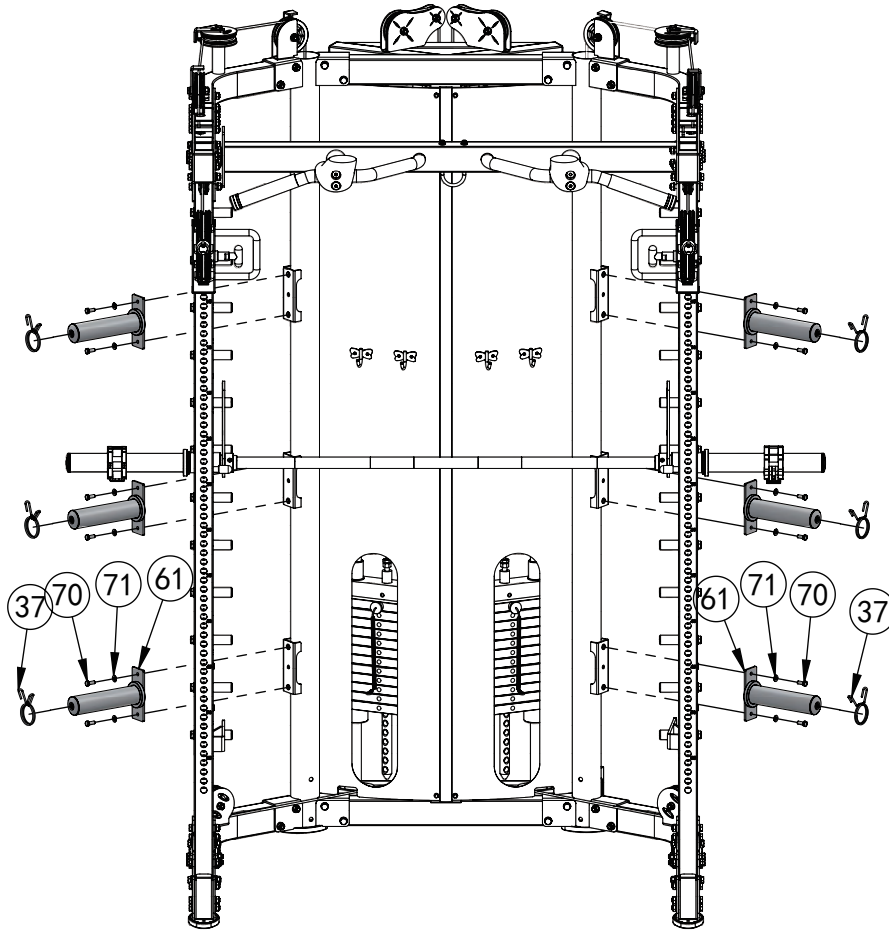

NO.	DESCRIPTION	NOTE	QTY
37	Spring Collar	φ50	6
61	Barbell Plate Holder	Assembly Part	6
70	Hexagonal Head Bolt	M8×20	12
71	Flat Gasket	φ8	12



## ASSEMBLY STEP 22

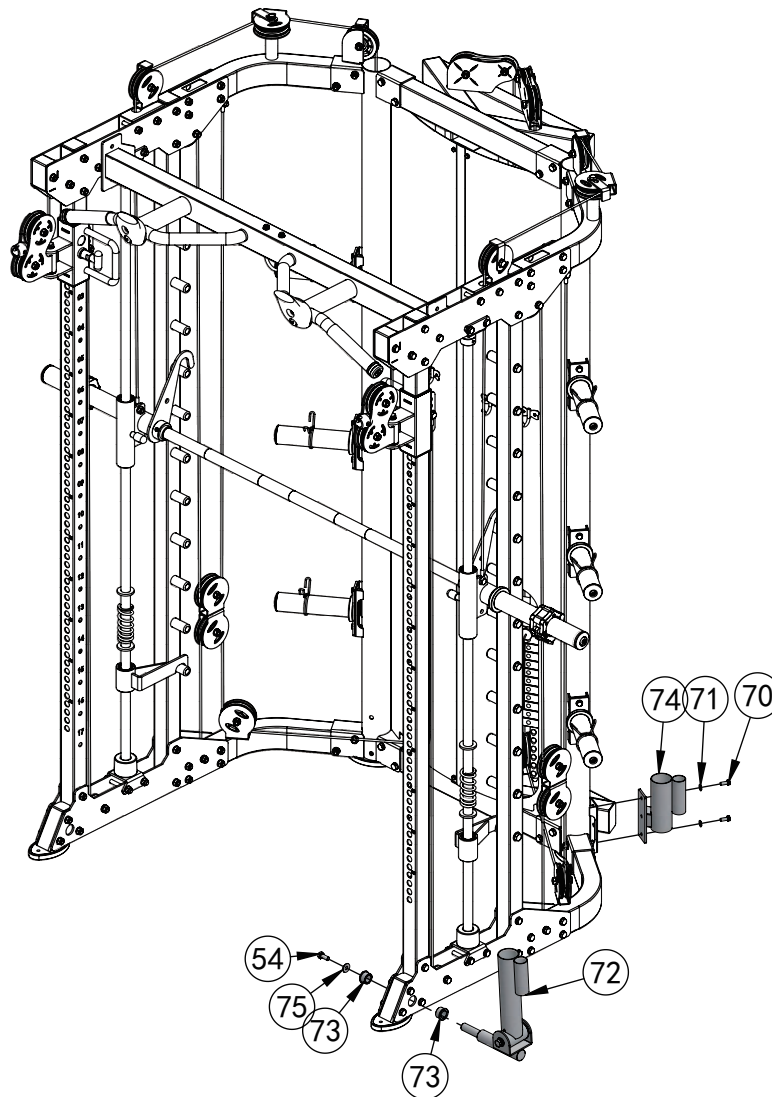

NO.	DESCRIPTION	NOTE	QTY
54	Hexagonal Head Bolt	M10×25	1
70	Hexagonal Head Bolt	M8×20	2
71	Flat Gasket	φ8	2
72	Core Trainer	Assembly Part	1
73	Powder Metallurgy Sleeve	φ33×φ29×φ20×18	2
74	Barbell Bar Cover	Welding Part	1
75	Large Flat Gasket	φ25*φ10*2	1

## ASSEMBLY STEP 23

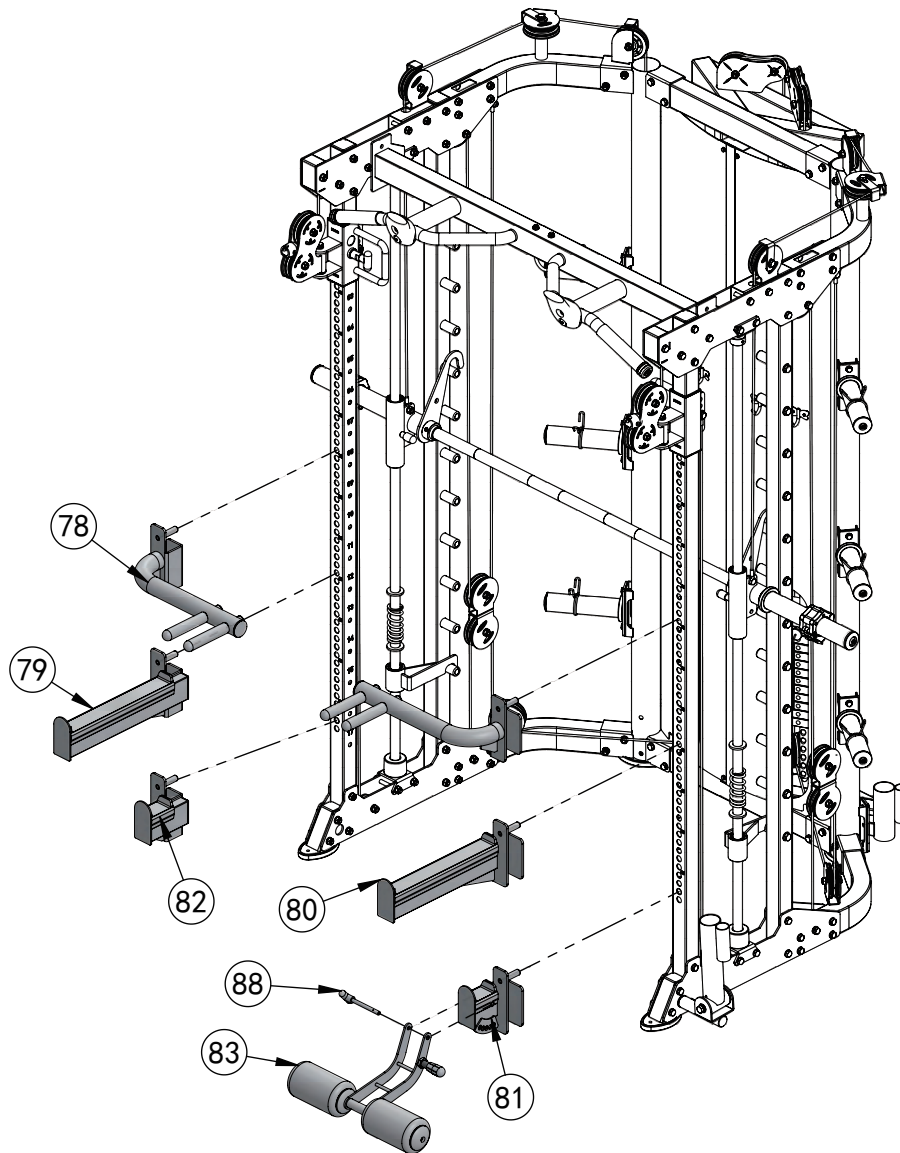

NO.	DESCRIPTION	NOTE	QTY
77	Dip Bar Left	Assembly Part	1
78	Dip Bar Right	Assembly Part	1
80	Barbell Rod Holder Left	Assembly Part	1
81	Barbell Rod Holder Short Left	Assembly Part	1
82	Barbell Rod Holder Short Right	Assembly Part	1
79	Barbell Rod Holder Right	Assembly Part	1
83	Leg Curl Tube	Assembly Part	1
88	T-shaped Pin	φ10*100	1

## ASSEMBLY STEP 24

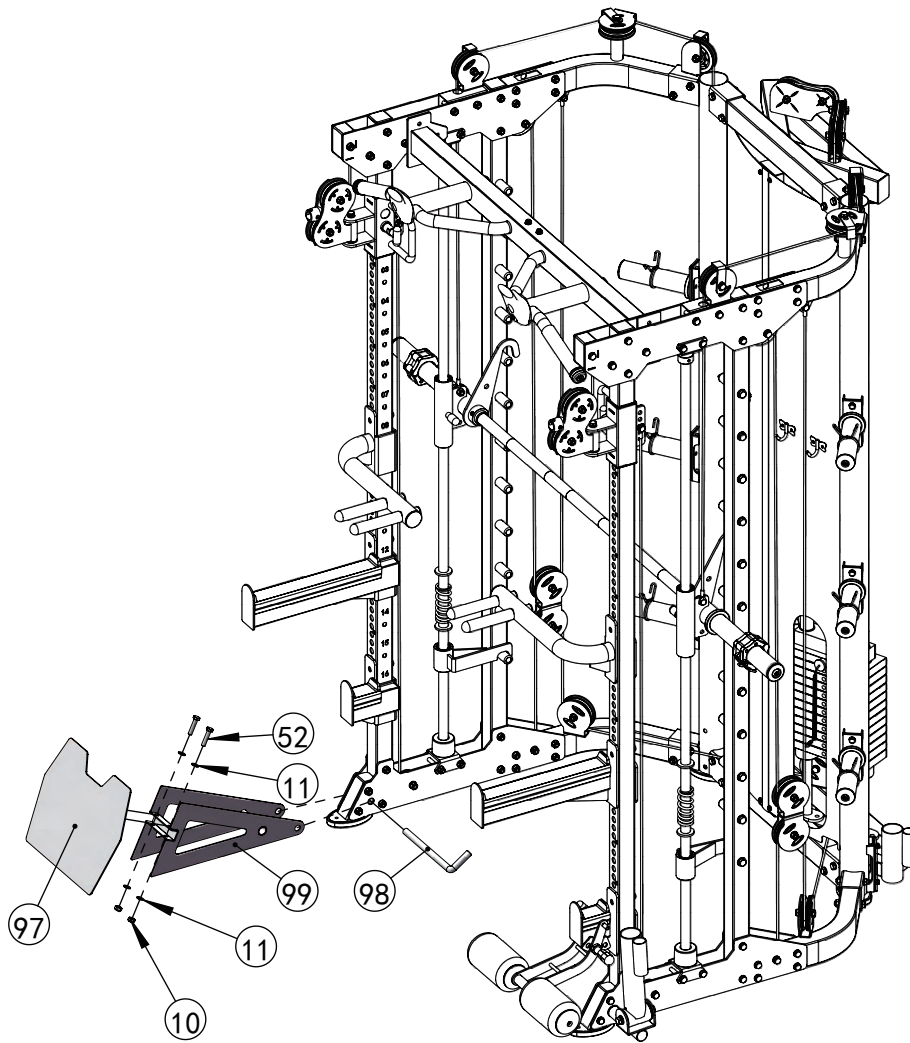

NO.	DESCRIPTION	NOTE	QTY
97	Foot Plate	Assembly Part	1
98	Fixed Spring Rope L-shaped Pin	$\phi 17 \times 250 \times 77L$	1
99	Foot Plate Support Weldment	Welding Part	1
11	Flat Gasket	$\phi 10$	4
52	Hexagonal Head Bolt	M10 $\times$ 45	2
10	Lock Nut	M10	2

## ACCESSORY

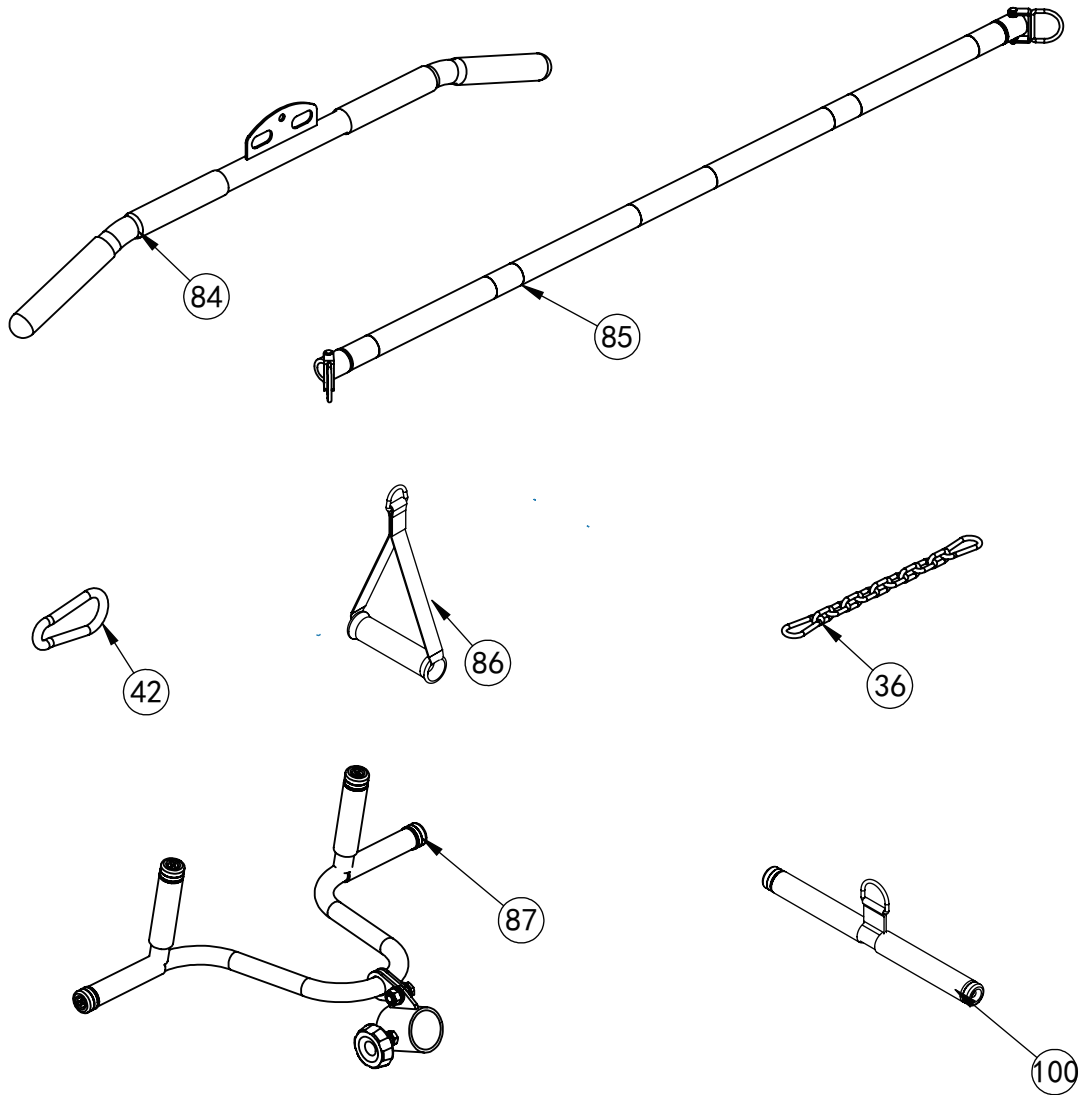

NO.	DESCRIPTION	NOTE	QTY
36	Chain + Safety Hook	Assembly Part	3
42	Safety Hook	Standard Part	2
84	Long Bar	Assembly Part	1
85	Ship Rod	Assembly Part	1
86	Hand Belt	Single Ring	2
87	Pull Lift Device	Assembly Part	1
100	Short Straight Bar	Assembly Part	1